



Studio Slimline Range

Balanced Flue - Stone Chippings and Log
with Thermostatic Remote Control



User, Installation & Servicing Instructions

IMPORTANT

THE OUTER CASING, FRONT AND GLASS PANEL BECOME EXTREMELY HOT DURING OPERATION AND WILL RESULT IN SERIOUS INJURY AND BURNS IF TOUCHED. IT IS THEREFORE RECOMMENDED THAT A FIREGUARD COMPLYING WITH BS 8423 (LATEST EDITION) IS USED IN THE PRESENCE OF YOUNG CHILDREN, THE ELDERLY OR INFIRM.

This product contains a heat resistant glass panel. This panel should be checked during Installation and at each servicing interval. If any damage is observed on the front face of the glass panel (scratches, scores, cracks or other surface defects), the glass panel must be replaced and the appliance must not be used until a replacement is installed. Under no circumstances should the appliance be used if any damage is observed, the glass panel is removed or broken.

It is essential that ALL hooks that retain the glass frame are engaged correctly. Under no circumstances should the appliance be operated if the hooks are not in the correct position.

These Instructions must be left with the appliance for future reference and for consultation when servicing the appliance. Please make the customer aware of the correct operation of the appliance before leaving these instructions with them.

The commissioning sheet found on Page 3 of this Instruction manual must be completed by the Installer prior to leaving the premises.

PR2015.13.1.2023

CONTENTS

Studio Slimline Balanced Flue

Covering the following models:

MODEL		STUDIO 1 SLIMLINE	STUDIO 2 SLIMLINE
Log Effect	Natural Gas	123-191	123-056
	LPG	123-489	123-518
White Stone Effect	Natural Gas	123-238	123-004
	LPG	123-642	123-529

Appliance Commissioning Checklist3

User Instructions4

Installation Instructions15

Site Requirements..... 17

Technical Specification 19

Installation of the Appliance 22

Commissioning 42

Servicing Requirements43

Fault Finding..... 44

Servicing..... 46

Information Requirement - Gas Heaters 53

Spare parts list 54

Service Records 58



If you have purchased your stove or fire from an authorised stockist within our Expert Retailer Network, then automatically your product will carry a 2 year warranty as standard. The 2 year warranty can be further extended to a total warranty period of 5 years by registering your Gazco Stove or Fireplace within one month of the latter of the purchase date or installation date. Accordingly, the start date for the warranty period is the date of purchase. During the registration process, the Expert Retailer details will be required for your Extended Warranty to be activated. Any product purchased outside of our Expert Retailer Network will carry a standard 12 month, non-extendable warranty.

It is a condition of the Extended Warranty that the installation complies with the relevant Building Regulations and is carried out by a suitably trained and qualified individual (GasSafe in the UK or equivalent in other countries) with the certificate of installation and the Commissioning Report on Page 3 completed and retained by the end user.

Full terms and conditions are detailed in the Warranty Statement on the Gazco website www.gazco.com. In the event of any conflict of information the wording on the website shall prevail.

Important Note: Should any problems be experienced with your product, claims must first be submitted to the Expert Retailer where the appliance was purchased from who will offer immediate assistance or contact Gazco on your behalf.



It is a requirement of the Building Regulations 2010 that the installation of this appliance is notified to the Local Authority. It is the responsibility of the GasSafe registered installer to carry out this notification to the Local Authority via the GasSafe register Competent Persons Scheme in England and Wales (different rules apply in Scotland and Northern Ireland).

When the installation has been notified, GasSafe will send a Building Regulations Compliance Certificate to you containing details of the work completed. Please ensure that the person responsible for the installation of this appliance completes this notification and records it in the Appliance Commissioning Checklist on page 3.

IT IS YOUR RESPONSIBILITY TO COMPLY WITH THE BUILDING REGULATIONS AND BE ABLE TO PRODUCE THIS CERTIFICATE SHOULD IT BE REQUIRED IN THE FUTURE.

APPLIANCE COMMISSIONING CHECKLIST

To assist us in any guarantee claim please complete the following information:-

IMPORTANT NOTICE

Explain the operation of the appliance to the end user, hand the completed instructions to them for safe keeping, as the information will be required when making any guaranteed claims.

FLUE CHECK	PASS	FAIL
1. Flue Is correct for appliance		
2. Flue flow Test N/A		
3. Spillage Test N/A		
GAS CHECK		
1. Gas soundness & let by test		
2. Standing gas pressure	mb	
3. Appliance working pressure (on High Setting) Minimum Pressure Requirement: NG - 17.5mbar LPG - 34.5mbar NB All other gas appliances must be operating on full	mb	
4. Gas rate	m ³ /h	
5. Does Ventilation meet appliance requirements N/A		
SAFETY CHECK		
1. Check soundness of the Thermocouple connections - including tightness and lead integrity		
2. Glass checked to ensure no damage, scratches, scores or cracks		
3. Glass frame secured correctly and all screws replaced		
4. CO Alarm Fitted		
BUILDING CONTROL NOTIFICATION	YES	NO
1. Installer notified Local Authority of installation via Competent Persons Scheme?		

RETAILER AND INSTALLER INFORMATION

Retailer

Contact No......
Date of Purchase
Model No.
Serial No......
Gas Type

Installation Company.....

Engineer.....
Contact No......
GasSafe Reg No.
Date of Installation

USER INSTRUCTIONS

GENERAL

Installation and servicing must only be carried out by a competent person whose name appears on the Gas Safe register. To ensure the engineer is registered with Gas Safe they should possess an ID Card carrying the following logo:



In all correspondence, please quote the appliance type and serial number, which can be found on the data badge located on a plate under the Main Burner.

Do not place curtains above the appliance: You must have 300mm clearance between the appliance and any curtains at either side.

If a shelf is fitted, a distance of 400mm above the appliance is required.

No furnishings or other objects should be placed within 1 metre of the front of the appliance.

If any cracks appear in the glass panels do not use the appliance until the panels have been replaced.

If, for any reason, the flue has to be removed from the appliance, the seals must be replaced in the inner spigot.

Do not obstruct the flue terminal in any way, i.e. by planting flowers, trees, shrubs etc. in the near vicinity, or by leaning objects against the terminal guard.

Do not put any objects on the terminal guard; it will lose its shape.

If you use a garden sprinkler, do not let quantities of water into the flue terminal.

This product is guaranteed for 5 years from the date of installation, as set out in the terms and conditions of sale between Gazco and your local Gazco retailer. Please consult with your local Gazco retailer if you have any questions. In all correspondence always quote the Model Number and Serial Number.

This appliance is not intended to be used by persons under the age of 12, persons with reduced physical, sensory or mental capabilities or persons with lack of experience and knowledge in the safe operation of the appliance.

The appliance may be operated by persons above the age of 12 provided they have been instructed in the safe use of the appliance and that they understand the hazards involved. Persons above the age of 12 may also operate the appliance under the supervision of a responsible adult.

Cleaning and Maintenance of the appliance must be undertaken by a suitably qualified adult.

CHILDREN MUST BE SUPERVISED TO ENSURE THEY DO NOT PLAY WITH THE APPLIANCE.



IMPORTANT: NEVER position a television or screen above this appliance.

CO ALARMS

Building regulations require that whenever a new or replacement fixed gas burning appliance is installed in a dwelling, a carbon monoxide alarm complying with BS EN 50291-1 (latest edition) must be fitted in the same room as the appliance. Further guidance and recommendations on the installation of carbon monoxide alarms is available in BS EN 50292 (latest edition) and from manufacturers' instructions.

Provision of an alarm must not be considered a substitute for either installing the appliance correctly or ensuring regular servicing and maintenance of the appliance.

WARNING



In the event of a gas escape or if you can smell gas, please take the following steps:

- Immediately turn off the gas supply at the meter/emergency control valve
- Extinguish all sources of ignition
- Do not smoke
- Do not operate any electrical light or power switches (On or Off)
- Ventilate the building(s) by opening doors and windows
- Ensure access to the premises can be made

Please report the incident immediately to the National Gas Emergency Service Call Centre on 0800 111 999 (England, Scotland and Wales), 0800 002 001 (N. Ireland) or in the case of LPG, the gas supplier whose details can be found on the bulk storage vessel or cylinder.

The gas supply must not be used until remedial action has been taken to correct the defect and the installation has been recommissioned by a competent person.

OPERATING THE APPLIANCE

The appliance is operated by thermostatic remote control.

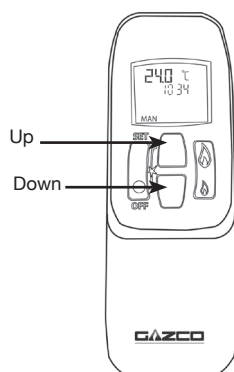

TURNING THE APPLIANCE ON

Your remote can control the gas fire from pilot ignition through to shut down.

To turn the fire on press the OFF button and the UP button simultaneously. You hear several short signals.

The pilot and main burner ignite and the remote is now in Manual Mode



IMPORTANT: YELLOW FLAMES TYPICALLY APPEAR WHEN THE APPLIANCE HAS REACHED NORMAL OPERATING TEMPERATURE. THIS CAN TAKE UP TO 30 MINUTES.



WARNING: IF THE APPLIANCE FAILS TO LIGHT OR BECOMES EXTINGUISHED IN USE, WAIT 3 MINUTES BEFORE ATTEMPTING TO RELIGHT.

There are 3 different modes available for controlling and operating the appliance:

1. Manual Mode
2. Temp Mode (Automatic)
3. Timer Mode (Automatic)

In **MANUAL MODE** you can:

- Turn on the main burner using the UP button.
- Regulate the flame from high to low and back.
- Turn off the burner leaving just the pilot burning.

In **TEMP MODE (Automatic)** you can:

- Set the room temperature so the thermostat in the remote automatically maintains that temperature.

In **TIMER MODE (Automatic)** the fire:

- Turns on and off according to the set time periods.
- Automatically regulates the room temperature during the set periods.



NOTE: When operating the fire in Thermostatic or Program mode, the pilot remains lit and the fire then automatically switches on to bring the room to the set temperature whether or not you are in the room.

NEVER LEAVE ANY COMBUSTIBLE MATERIALS WITHIN 1 METRE OF THE FRONT OF THE APPLIANCE.

SWITCHING BETWEEN MODES

Press the SET button to change to Temperature Mode. Press again to change to Timer Mode.

Keep pressing to run through all operating modes. These are:

- MAN
- DAY TEMP
- NIGHT TEMP
- TIMER and back to MAN

NOTE: MAN mode can also be reached by pressing either the UP or DOWN button.

MANUAL MODE

Press the OFF button and the UP button simultaneously. You hear several clicks and audible beeps as the fire begins the ignition process, (up to 30 seconds).

TURNING THE APPLIANCE OFF:

Press the OFF button to turn the appliance off.

FOR SAFETY, YOU MUST WAIT 30 SECONDS BEFORE LIGHTING THE FIRE AGAIN.

INCREASING THE FLAME HEIGHT:

Press the UP button once to increase flame height one stage. Press and hold the UP button to increase to maximum.

DECREASING THE FLAME HEIGHT:

Press the DOWN button once to decrease flame height one stage. Press and hold the DOWN button to decrease to minimum. At the lowest point the fire goes to 'Standby Mode' (Only Pilot lit).



NOTE: While pressing a button a symbol indicating transmission appears on the display. The receiver confirms transmission with a sound signal.

TEMP MODE (AUTOMATIC)

The display shows the current **room** temperature.

To increase or decrease the fire's output:

Press the SET button to select either the DAY TEMP or the NIGHT TEMP mode by briefly pressing the SET button.

Hold the SET button until the TEMP display flashes and then let go.

Set the desired temperature with the UP and DOWN arrows. (Minimum temperature 5°C, maximum 40°C or 40°F to 99°F when Fahrenheit is the preferred option).

Press the OFF button to stop the display flashing or wait to return to TEMP mode.



NOTE: If you set a temperature that is beneath the current room temperature, the fire automatically switches to PILOT (Stand by).

If you would like the Night temperature control to turn off then decrease the temperature until [-] is displayed.

TIMER MODE (AUTOMATIC)

There are two programmable settings you can make over a 24 hour period, P1 and P2. These are normally used to provide an early morning and evening setting for each working week:

- P1 + ● = Start Timed Setting 1
- P1 + > = End of Timed Setting 1
- P2 + ● = Start Timed Setting 2
- P2 + > = End of Timed Setting 2

P1 - Program 1 for a Timed Setting

Press the SET button until the TIMER mode is displayed.

Hold the SET button. The display flashes the current time for P1. **While the time displayed is flashing you can alter the hours and minutes set.**

To set the time your fire first lights, change P1 ●
 — Press the UP button to alter the hour.
 — Press the DOWN button to alter the minutes in 10 minute increments.

Press SET again to move to the end setting for P1 >
 This is the time your Studio first shuts down:
 — Press the UP button to alter the hour.
 — Press the DOWN button to alter the minutes.

P2 - Program 2 for a Timed Setting

Use the same steps outlined in P1 to change the setting for P2.

If you have already set P1 and want to alter the setting for P2 only:

- Press the SET button until TIMER mode is displayed.
- Hold the SET button **until the display flashes the current time** for P1 ●.
- Press the SET button once again to scroll past the settings for P1 ● and P1 >.

With the time still flashing:

- Press the UP button to alter the hour.
- Press the DOWN button to alter the minutes.

Once all four times are set press the OFF button.

To view existing settings:

- Select Timer Mode.
- Press and briefly hold the SET button you see the start time for P1.
- Repeat the above step for the start and end of each program.

Low Battery

"BATT" is displayed on the remote when its batteries need replacement.

Setting the time

Simultaneously press the up and down buttons.

Press the up button to set the hour and the down button to set the minutes.

Press OFF to return to the manual mode or simply wait.

Setting the °C/24 Hour or °F/12 Hour clock

Press OFF and the down arrow until the display changes from °C/24 hour clock to °F/12 hour clock and vice versa.



If the remote is removed, lost or damaged, signals transmitted to the receiver cease. Your fire will go to standby (pilot) mode after 6 hours.

TROUBLESHOOTING



IMPORTANT: In the unlikely event that the handset fails to communicate correctly with the appliance it may be necessary to turn off the gas supply at the isolation valve until any problems can be resolved.

The gas meter and isolation valve can be located outside in a meter box, under the stairs, beneath the kitchen sink or in the garage. Whilst this list is not exhaustive, it is important to be able to identify the location of the valve in case of any gas emergency.

To turn off the gas supply, simply turn the handle so the lever is at 90 degrees to the upright gas pipe.

If you smell gas, open doors and windows and never operate any electrical switches. Immediately call the Gas Emergency Services on 0800 111 999.

CHANGING THE APPLIANCE BATTERIES

The appliance batteries are located behind the wall plate.

Undo the two screws securing the wall plate and remove, see Diagram.

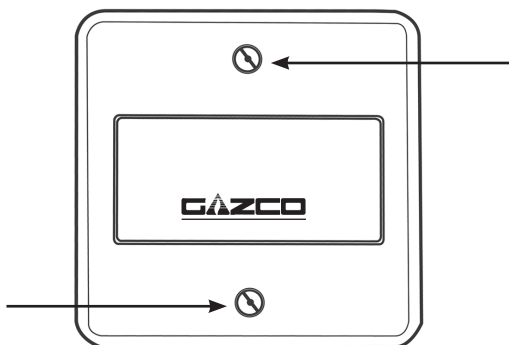

Unclip the battery holder from the wall plate and remove the old batteries.

Correctly position the four new AA size batteries into the battery holder. Re-assemble the battery holder as shown in Diagram.

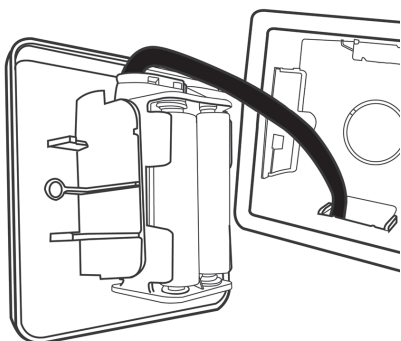

PLEASE ENSURE NO WIRES ARE TRAPPED BEFORE REPLACING THE WALL PLATE. THE TOUCH PAD LEAD IS EASILY DAMAGED.

CLEANING THE APPLIANCE

Make sure the appliance and surrounds are cool before cleaning.

Use:

- A dry cloth or stainless steel product to clean the polished plate.
- A damp cloth for the painted frame.
- Soap and water to clean the glass.

OPENING THE GLASS WINDOW

Steel, Verve or Glass Frame

If fitted with a Steel, Verve or Glass Frame, this needs to be removed first:

Lift the frame upwards off its four support brackets, see Diagram.

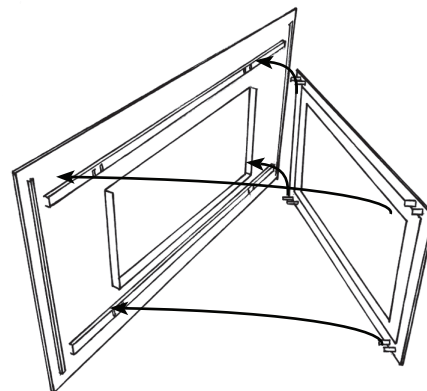

ALL MODELS

To open the glass door use the hexagon key provided.

Release the window locks by moving them from shut to open towards the outer edges.

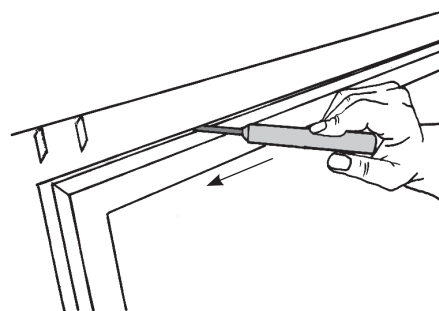

To completely remove the glass front:

Support the frame and lower it gently forward down to its natural stop position. **DO NOT EXERT PRESSURE ON THE DOOR ONCE THERE IS RESISTANCE.**

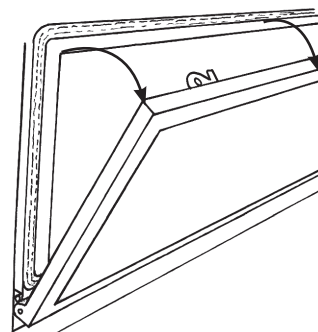

Remove the securing spring clip from the bottom-right of the window frame.

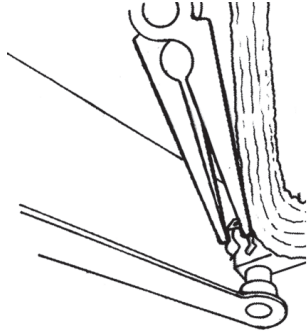

With the window frame in an upright position slide the frame to the left so that it comes off the left hinge pin, see Diagram.

Still keeping the frame upright drop the left side down and forward slightly.

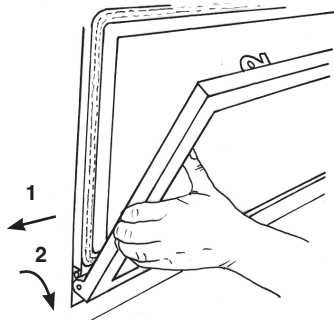

Slide the frame to the right so it comes off the **right** (all models) **and middle** (Studio 2 only) hinge pins. The window frame should now be free.

Place carefully to one side.

Refit the Window Frame Assembly in reverse order.

When closing the door ensure the door catches are fully engaged.



UNDER NO CIRCUMSTANCES SHOULD THE APPLIANCE BE USED WITHOUT THE CATCHES HOLDING THE DOOR IN PLACE.

ARRANGEMENT OF THE FUEL BED

ADVICE ON HANDLING AND DISPOSAL OF FIRE CERAMICS



The fuel effect and liners of this appliance are made from Refractory Ceramic Fibre (RCF), a material which is commonly used for this application.

Protective clothing is not required when handling these articles, but we recommend you follow normal hygiene rules of not smoking, eating or drinking in the work area and always wash your hands before eating or drinking.

To ensure that the release of RCF fibres are kept to a minimum, during installation and servicing a HEPA filtered vacuum is recommended to remove any dust accumulated in and around the appliance before and after working on it. When servicing the appliance it is recommended that the replaced items are not broken up, but are sealed within heavy duty polythene bags and labelled as RCF waste.

RCF waste is classed as stable, non-reactive hazardous waste and may be disposed of at a licensed landfill site.

Excessive exposure to these materials may cause temporary irritation to eyes, skin and respiratory tract; wash hands thoroughly after handling the material.

LOG LAYOUT

LOGS MUST BE POSITIONED ACCORDING TO THE FOLLOWING INSTRUCTIONS TO GIVE THE CORRECT FLAME EFFECT

STUDIO 1 LAYOUT

Ensure the burner tray is clean and free from any debris.

All logs can be identified by a letter (A - D) on their underside.

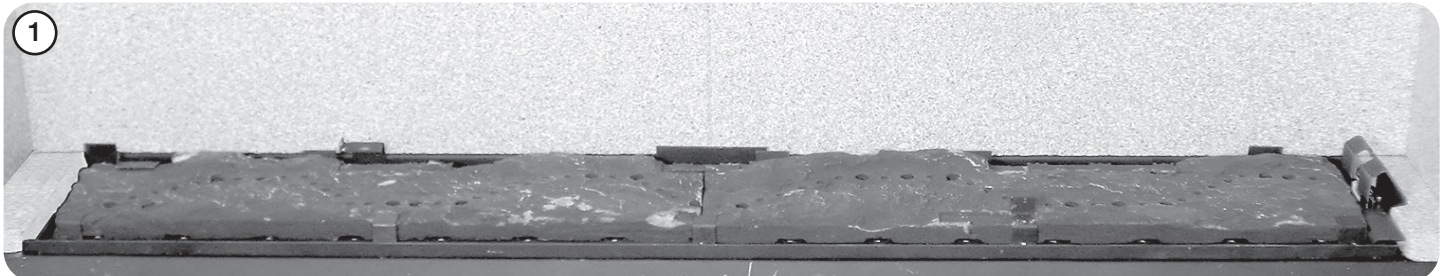

Position Log A between the two tabs at the back of the burner tray, see Diagram 2. The left hand side should rest on the tab at the back of the burner tray and be pushed up to the supporting lip, see Diagram 2 Detail.

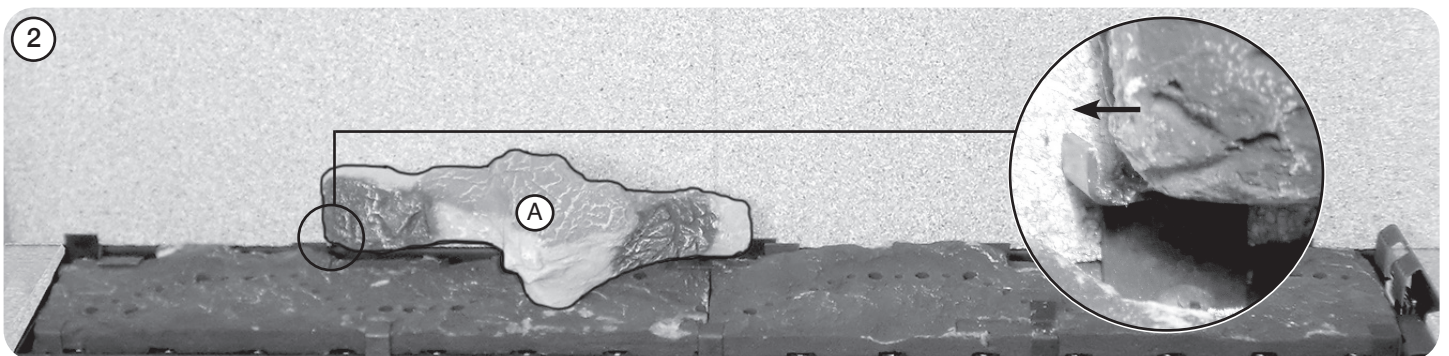

Place the left hand end of Log B against the back right tab on the burner tray, see Diagram 3. Ensure that the front branch is in line with the front of the burner tray.

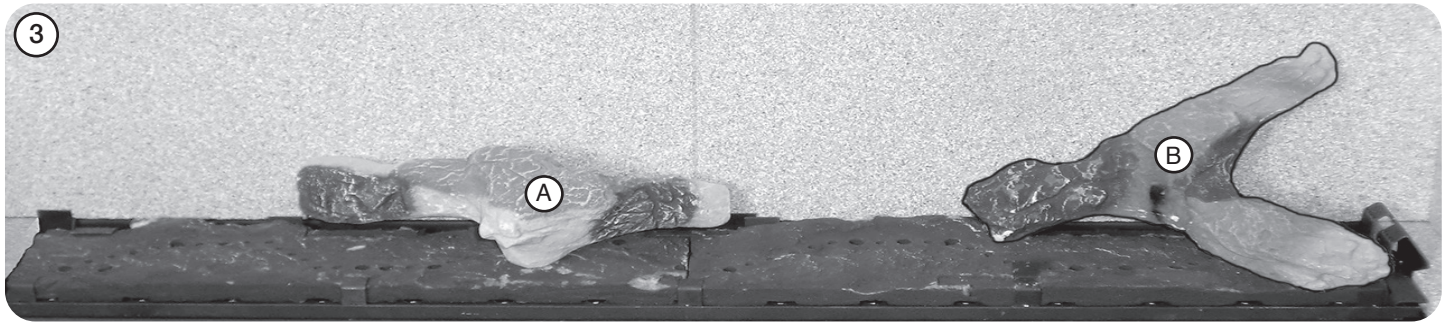

Rest the left end of Log C on the bottom left vermiculite panel in the back left corner, see Diagram 4. The right end of Log C rests across Log A with the small front branch resting on the burner tray.

Engage the left hand end of Log D with the right hand end of Log A. The right hand end of Log D fits in front of the metal stop on the front of the burner tray.

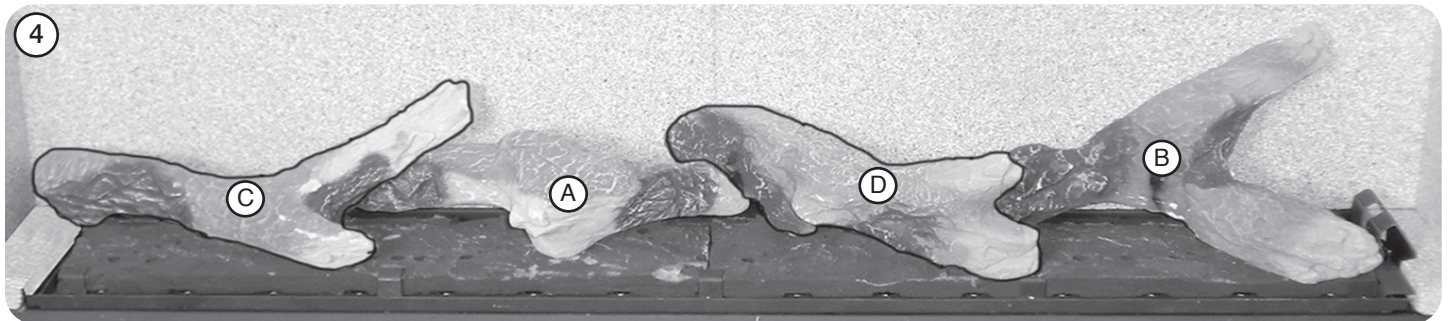

Separate the Embaglow material into smaller pieces and pull into shape to create a fine layer.

Springly spread an amount of the Embaglow fibres provided, covering the ports in the burner tray, see Diagram 5. Ensure the material is placed loosely to create a random glow. Take care not to use more than half a packet per application.

WARNING - DO NOT PLACE NEAR THE PILOT AREA.



STUDIO 2 LAYOUT

Ensure the burner tray is clean and free from any debris.

All logs can be identified by a letter (A, B, C, 2 x D, E) on their underside.

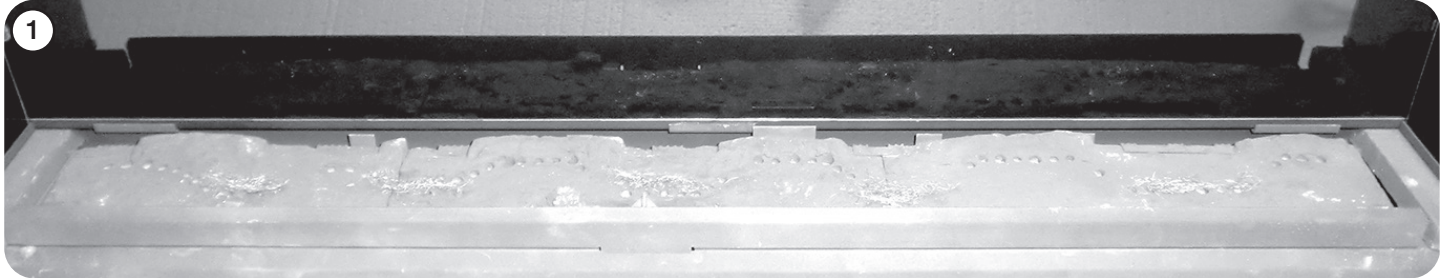

Position Log A between the two tabs at the back of the burner tray, see Diagram 2. Ensure that it is pushed up against the back panel and the end of Log A is on the raised section of the burner.

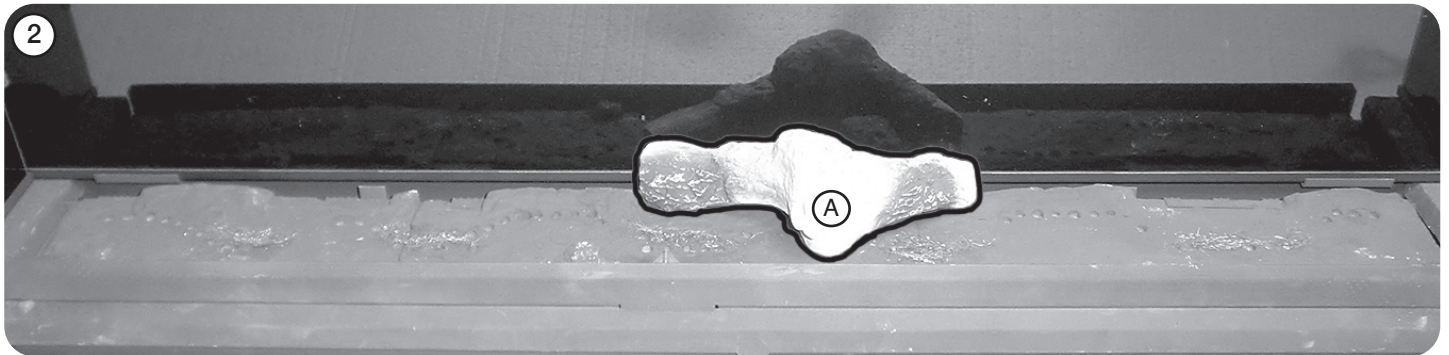

Place the left hand end of Log B against the back right tab on the burner tray, see Diagram 3. Ensure that the front branch is in line with the front of the burner tray.

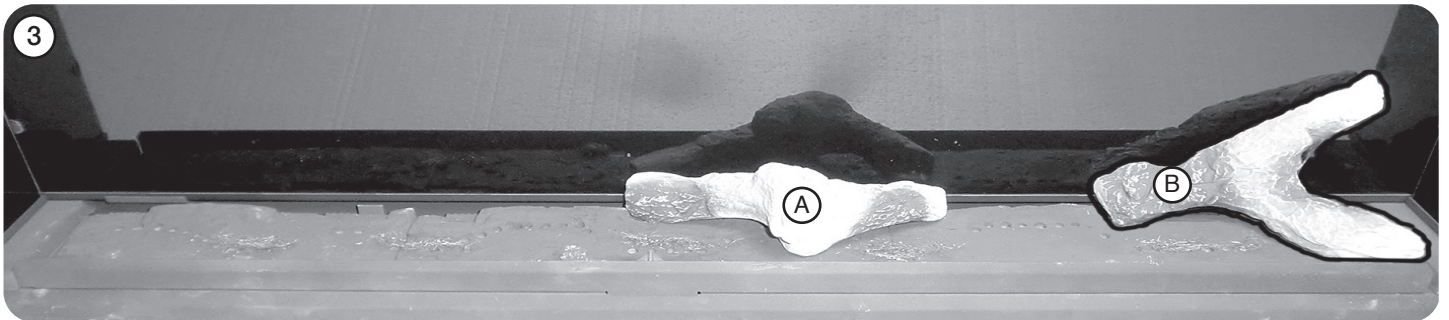

Rest the left end of Log D on the bottom left vermiculite panel, see Diagram 4. The right end of Log D should be touching the rear liner.

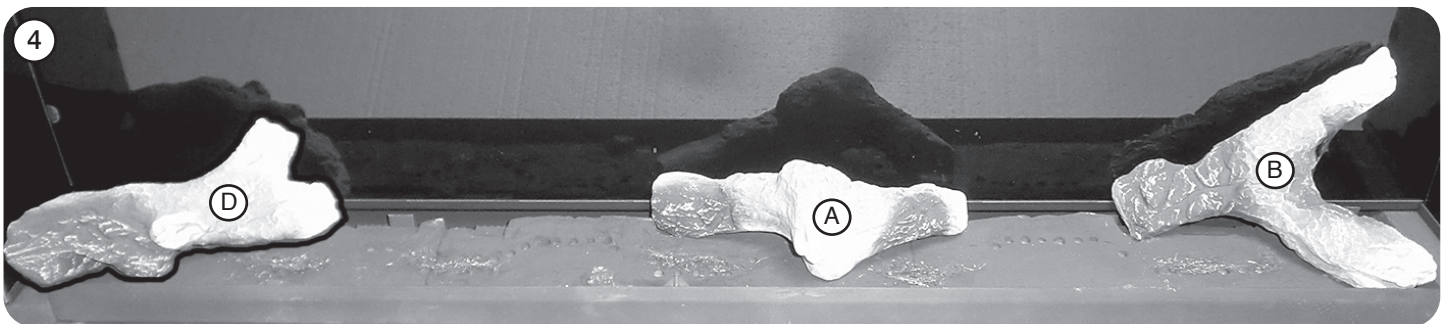

Engage the left hand end of Log D with the right hand end of Log A. The right hand end of Log D fits in front of the metal stop on the front of the burner tray.

Place the left hand side of Log C to the rear of the burner tray against the tab and the right hand side at the front of the burner with the rear section resting on Log A.

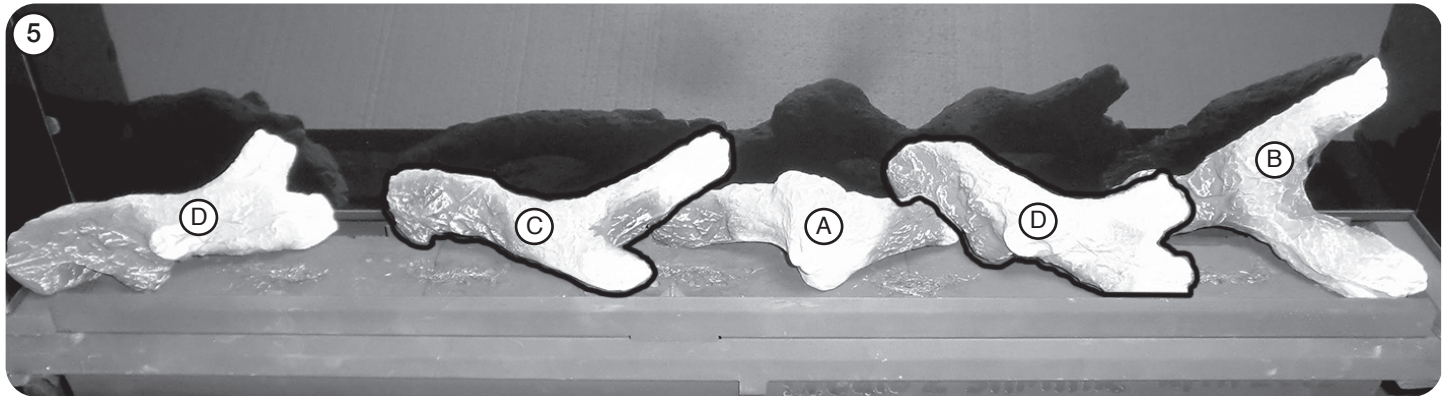

Log E rests against logs C and D with the lower end located in the cutout in the burner, see Diagram 6.

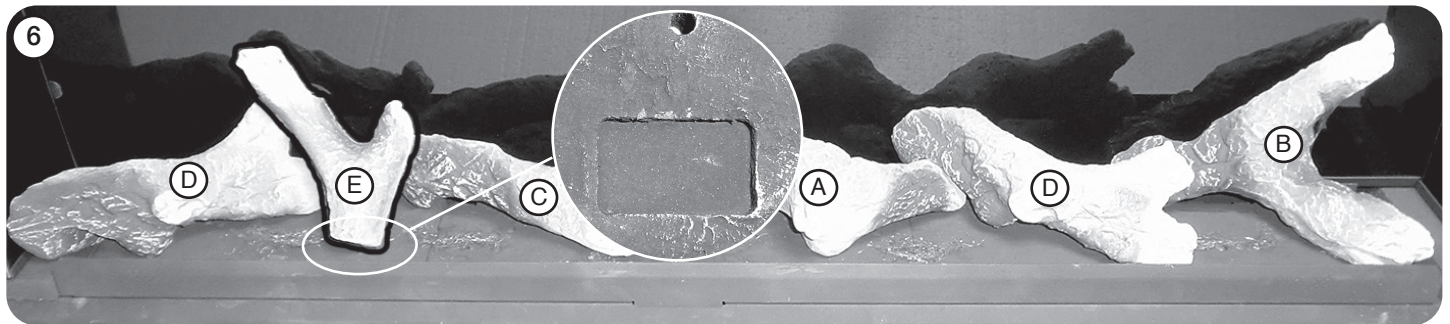

Separate the Embaglow material into smaller pieces and pull into shape to create a fine layer.

Sparingly spread an amount of the Embaglow fibres provided, covering the ports in the burner tray, see Diagram 20. Ensure the material is placed loosely to create a random glow. Take care not to use more than half a packet per application.

WARNING - DO NOT PLACE NEAR THE PILOT AREA.



STONE/ GLASS FUEL EFFECT LAYOUT

To use the white stone or glass granule fuel effect, apply according to the following instructions to give the correct flame effect.

Ensure the burner tray is clean and free from any debris, see Diagram 1.

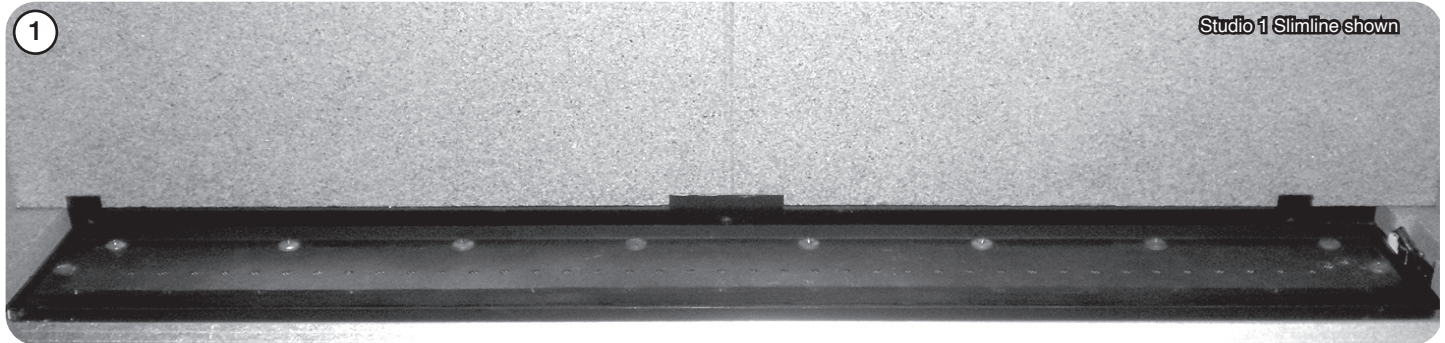

Fill the tray making sure the effect is flattened so it is level with the rim of the tray.
DO NOT OVERFILL THE BURNER TRAY.

TAKE CARE NOT TO SPILL EFFECT INTO THE PILOT AREA FRONT CHANNEL OR GAP AT REAR OF TRAY,
see Diagram 2.

ONLY GENUINE GAZCO PARTS CAN BE USED IN THIS APPLIANCE.



FLAME FAILURE DEVICE

This is a safety feature incorporated on this appliance which automatically switches off the gas supply if the pilot goes out and fails to heat the thermocouple.

IF THIS OCCURS DO NOT ATTEMPT TO RELIGHT THE APPLIANCE FOR 3 MINUTES.

RUNNING IN

During initial use of a new GAZCO appliance a strong odour will be encountered as various surface coatings become hot for the first time. Although these odours are harmless it is recommended that the appliance is operated on maximum for 4 to 8 hours in order to fully burn off these coatings. After this period the odours should then disappear.

If the odour persists, please contact your installer for advice.

During the first few hours of burning there may be discolouration of the flames. This will also disappear after a short period of use.

VENTILATION

This appliance requires no additional ventilation.

However, it will be necessary to ensure the housing for the appliance has vents provided to allow air to circulate and prevent overheating.

INSTALLATION DETAILS

Your installer should have completed the commissioning sheet at the front of this book. This records the essential installation details of the appliance. In all correspondence always quote the Model number and Serial number.

PILOT AREA WHITENING

Gas fire owners (not exclusive to Gazco) have reported issues of whitening around the pilot areas on their Conventional Flue glass fronted products. These white marks can also appear on glass or enamel panels inside the fire and on the inside of the glass.

The cause of this has been identified as Silica Dioxide. Gazco can confirm that there are no Silicone products used in our conventionally flued fires and is therefore forming from sources external to the appliance. Silica Dioxide can be widely found in domestic cleaning products, cosmetics, scented room diffusers and candles.

To reduce this problem, Gazco would recommend the removal of any products that could possibly contain Silica Dioxide from the room the fire is situated in. In addition to this, the whitening appears to be worse when the product is left for long periods of time in the pilot only position. This should be reduced where customers are experiencing this problem.

HOT SURFACES

Parts of this appliance become hot during normal use.

Regard all parts of the appliance as a working surface.

Provide a suitable fire guard to protect young children and the infirm.

APPLIANCE WILL NOT LIGHT

If you cannot light the appliance:

Check and change the batteries in the remote handset.

Check and change the wall plate batteries.

Consult your Gazco retailer or installer if the Studio still does not light.

SERVICING



Servicing and Support

To keep your appliance looking and performing at its best, it must be serviced annually. This service must be undertaken by a suitably qualified individual and your retailer can organise this for you. Alternatively, Gazco offer a manufacturers premium service with our friendly team of qualified engineers which can be booked at www.gazco.com/support

In all correspondence always quote the Model number and the Serial number which may be found on the Commissioning Checklist (Page 3).

INSTALLATION INSTRUCTIONS

APPLIANCE LOCATION



NOTE: THIS APPLIANCE HAS BEEN PRIMARILY DESIGNED TO BE RECESSED INTO THE INTERNAL BRICKWORK OF A STANDARD CAVITY WALL. HOWEVER, IT IS ALSO POSSIBLE TO INSTALL THE APPLIANCE INTO A FALSE CHIMNEY BREAST CONSTRUCTED OF STUDWORK AND HEAT RESISTANT CLADDING.

If this appliance is fitted at floor level (giving a visible opening located 193mm from the floor) then it will require a hearth to protect the floor.

The hearth should have a minimum non combustible thickness of 12mm, projecting 300mm in front and 150mm either side of the base of the appliance.

The three methods of studwork installation are:

Frame (see Installation Instructions).

Edge (see Installation Instructions).

Cool Wall (see Installation Instructions).

This appliance must stand on a non-combustible platform that is at least 12mm thick.



NOTE: WHEN INSTALLING THIS APPLIANCE USING THE 'EDGE' OPTION IT IS RECOMMENDED THAT THE WALL IS FINISHED WITH EITHER SLIPS OR TILES MANUFACTURED FROM STONE OR SIMILAR NATURAL MATERIALS. IF SUCH MATERIALS ARE USED IT IS RECOMMENDED THAT THEY ARE CUT INTO FOUR OR MORE SECTIONS TO PREVENT CRACKING.

RESIN BASED MATERIALS (EG MICRO MARBLE) ARE NOT USUALLY RECOMMENDED DUE TO THE EFFECT OF HEAT ON RESINS. HOWEVER THEY CAN BE USED IF THEY HAVE BEEN MANUFACTURED FOR USE AT ELEVATED TEMPERATURES WITHOUT PRODUCING ANY ODOURS OR STAINING.

A combustible shelf must be:

- Maximum 150mm in depth.
- Minimum 400mm high above the appliance.

A combustible side wall must be a minimum of 150mm from the appliance.

This appliance is not suitable for installation onto or against a combustible wall. Remove all combustible material from the area shown, see Diagrams.

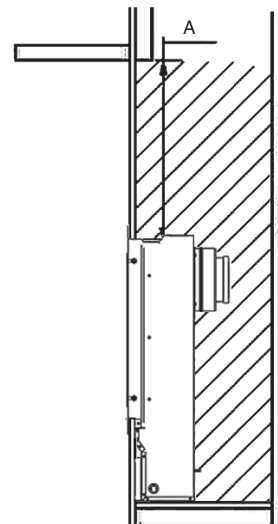
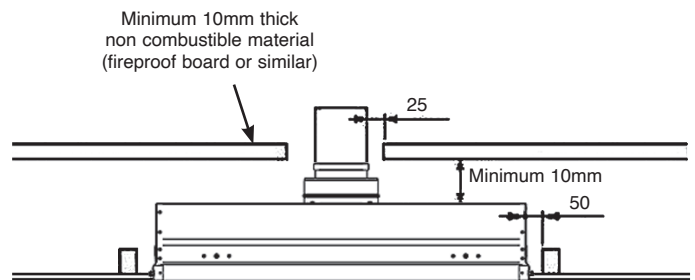
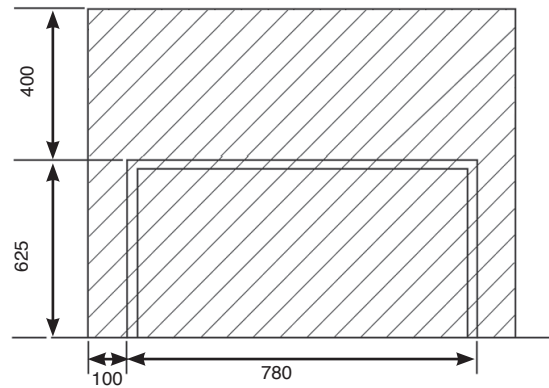

DIMENSION A	
Studio Slimline 1	400
Studio Slimline 2	700

SAFETY PRECAUTIONS

For your own and other's safety, you must install this appliance according to local and national codes of practice. Failure to install the appliance correctly could lead to prosecution. **Read these instructions before installing and using this appliance.**

These instructions must be left intact with the user.

Do not attempt to burn rubbish on this appliance.

Keep all plastic bags away from young children.

Do not place any object on or near to the appliance and allow adequate clearance above the appliance.

IF THE APPLIANCE IS EXTINGUISHED OR GOES OUT IN USE, WAIT 3 MINUTES BEFORE ATTEMPTING TO RELIGHT THE APPLIANCE.



**IMPORTANT: REFER TO DATA BADGE AND TECHNICAL SPECIFICATION AT THE FRONT OF THE MANUAL TO ENSURE THE APPLIANCE IS CORRECTLY ADJUSTED FOR THE GAS TYPE AND CATEGORY APPLICABLE IN THE COUNTRY OF USE.
FOR DETAILS OF CHANGING BETWEEN GAS TYPES REFER TO SERVICING, REPLACING PARTS.**

UNPACKING

Remove the appliance from its packaging, and check that it is complete and undamaged.

Put the loose ceramic parts to one side so that they are not damaged during installation.

SITE REQUIREMENTS

FLUE & CHIMNEY REQUIREMENTS

Note: This appliance must only be installed with the flue supplied.

You must adhere to the following:

The flue must be sited in accordance with BS5440: Part 1 (latest edition), see Diagram.

Fit a guard to protect people from any terminal less than 2 metres above any access such as level ground, a balcony or above a flat roof.

All horizontal flues must be securely fixed and fire precautions followed in accordance with local and national codes of practice.

To measure for a horizontal terminal decide on the terminal position.

Measure the height from the top of the appliance to the centre of the required outlet.

For minimum and maximum flue dimensions see next section.

Support the opening of a masonry installation with a lintel.

Only the horizontal terminal section can be reduced in size.

REAR FLUE

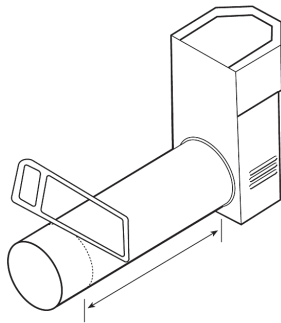

Terminal dimensions:

395 x 200 x 200 mm (H x W x D)

Guard supplied

Cut to length as required on site.

Decide on the terminal position.

Measure the height from the finished hearth level/ base of the appliance to the centre of the required hole.

A masonry installation requires the addition of a suitable lintel to support the opening. Refer to Installation Instructions, Technical Information for details of the flue length.

NOTE - Carefully consider:

- a) Terminal positions
- b) Flue supports
- c) Weatherproofing
- d) Fire precautions

For all the above options, you must conform to local and national codes of practice.

Use only Gazco supplied flue on this appliance.

A guard (supplied) must be fitted to any terminal less than 2 metres above any access such as level ground, a balcony or above a flat roof.

TIMBER FRAMED BUILDINGS

It will be necessary to provide additional clearance when the flue passes through a wall containing any combustible materials so as to prevent a fire hazard.

The hole through which the flue will pass, must have a steel sleeve which is positioned so that an air gap of at least 25mm is maintained between the outer surface of the flue, and any part of the sleeve.

For further guidance on the installation of gas appliances in timber framed buildings, contact your local buildings control authority.

GAS SUPPLY

This appliance is intended for use on a gas installation with a governed meter.

Before installation, ensure that the local distribution conditions (identification of the type of gas and pressure) and the adjustment of the appliance are compatible.

Ensure the gas supply delivers the required amount of gas and is in accordance with the rules in force.

Soft copper tubing can be used on the installation and soft soldered joints outside the appliance.

If it is intended to conceal the gas supply within the wall cavity, there must be no joints in any part of the supply that are not readily accessible when the appliance has been installed.

A factory fitted isolation device is part of the inlet connection; no further isolation device is required.

All supply gas pipes must be purged of any debris that may have entered prior to connection to the appliance.

The gas supply enters through the silicone panel located on the **left-hand** REAR or BASE of the outer box. Slit with a sharp knife before passing the supply pipe through.

The gas supply must be installed in a way that does not restrict the removal of the appliance for servicing and inspection.

The supply pipe may be installed in several ways.

- 1) By drilling a hole straight through the outside wall. There is a cutout in the back panel of the appliance to allow the pipe to be concealed within the appliance.
- 2) The gas pipe can be concealed by cutting a channel in the wall. All current regulations must be adhered to and no pipe joint must be concealed in the wall.

VENTILATION

This appliance requires no additional ventilation.

However, it will be necessary to ensure the housing for the appliance has vents provided to allow air to circulate and prevent overheating.

CO ALARMS

Building regulations require that whenever a new or replacement fixed gas burning appliance is installed in a dwelling, a carbon monoxide alarm complying with BS EN 50291-1 (latest edition) must be fitted in the same room as the appliance. Further guidance and recommendations on the installation of carbon monoxide alarms is available in BS EN 50292 (latest edition) and from manufacturers' instructions.

Provision of an alarm must not be considered a substitute for either installing the appliance correctly or ensuring regular servicing and maintenance of the appliance.

INSTALLATION

TECHNICAL SPECIFICATION

Covering the following models:

MODEL		STUDIO 1 SLIMLINE	STUDIO 2 SLIMLINE
Log Effect	Natural Gas	123-191	123-056
	LPG	123-489	123-518
White Stone Effect	Natural Gas	123-238	123-004
	LPG	123-642	123-529

MODEL	GAS CAT.	GAS TYPE	WORKING PRESSURE	AERATION	INJECTOR	GAS RATE M ³ /H	INPUT KW (GROSS)		COUNTRY	
							HIGH	LOW		
Studio Slimline 1 Log Effect	I ₂ H	Natural (G20)	20mbar	2 x 6.5mm	170	0.492	5.2	3.5	GB, IE	
	I ₃ P	Propane (G31)	37mbar	2 x (25x15)	150	0.188	5.1	3.4		
Studio Slimline 1 Stone Effect	I ₂ H	Natural (G20)	20mbar	2 x 8mm	170	0.492	5.2	3.5		
	I ₃ P	Propane (G31)	37mbar	2 x (25x15)	150	0.188	5.1	3.4		
Studio Slimline 2 Log Effect	I ₂ H	Natural (G20)	20mbar	2 x 6.5mm	184	0.58	6.1	3.2		
	I ₃ P	Propane (G31)	37mbar	2 x 11mm Ø	185	0.249	6.6	3.5		
Studio Slimline 2 Stone Effect	I ₂ H	Natural (G20)	20mbar	2 x 8mm	184	0.58	6.1	3.9		
	I ₃ P	Propane (G31)	37mbar	2 x 14mm Ø	185	0.249	6.6	3.5		
Efficiency Class 1 - 82% / NO_x Class 4										
Flue Outlet Size Ø 100mm										
Flue Inlet Size Ø 150mm										
Gas Inlet Connection Size Ø 8mm										

i The net efficiency of this appliance has been measured as specified in EN613:2001 and the result after conversion to gross using the appropriate factor from Table E4 of SAP 2012 is 75%. The test data has been certified by Kiwa Nederland BV. The gross efficiency value may be used in the UK Government's Standard Assessment Procedure (SAP) for energy rating of dwellings.

TECHNICAL SPECIFICATION

This appliance has been certified for use in countries other than those stated. To install this appliance in these countries, it is essential to obtain the translated instructions and in some cases the appliance will require modification. Contact Gazco for further information.

PACKING CHECKLIST

Qty Description	Fixing Kit containing:
For Stone Chippings Layout	1 x Instruction Manual
1 White Stone Chippings	6 x Wood Screws
1 Liner Set	6 x Wall Plugs
	1 x Handset
For Log Layout	1 x Silicone Seal
1 Log Set	4 x AA cell batteries
1 Liner Set	1 x 9v cell batteries
1 Bag Embaglow material	1 x Wall box
	1 x Wall plate
	1 x Battery holder

DIMENSIONS

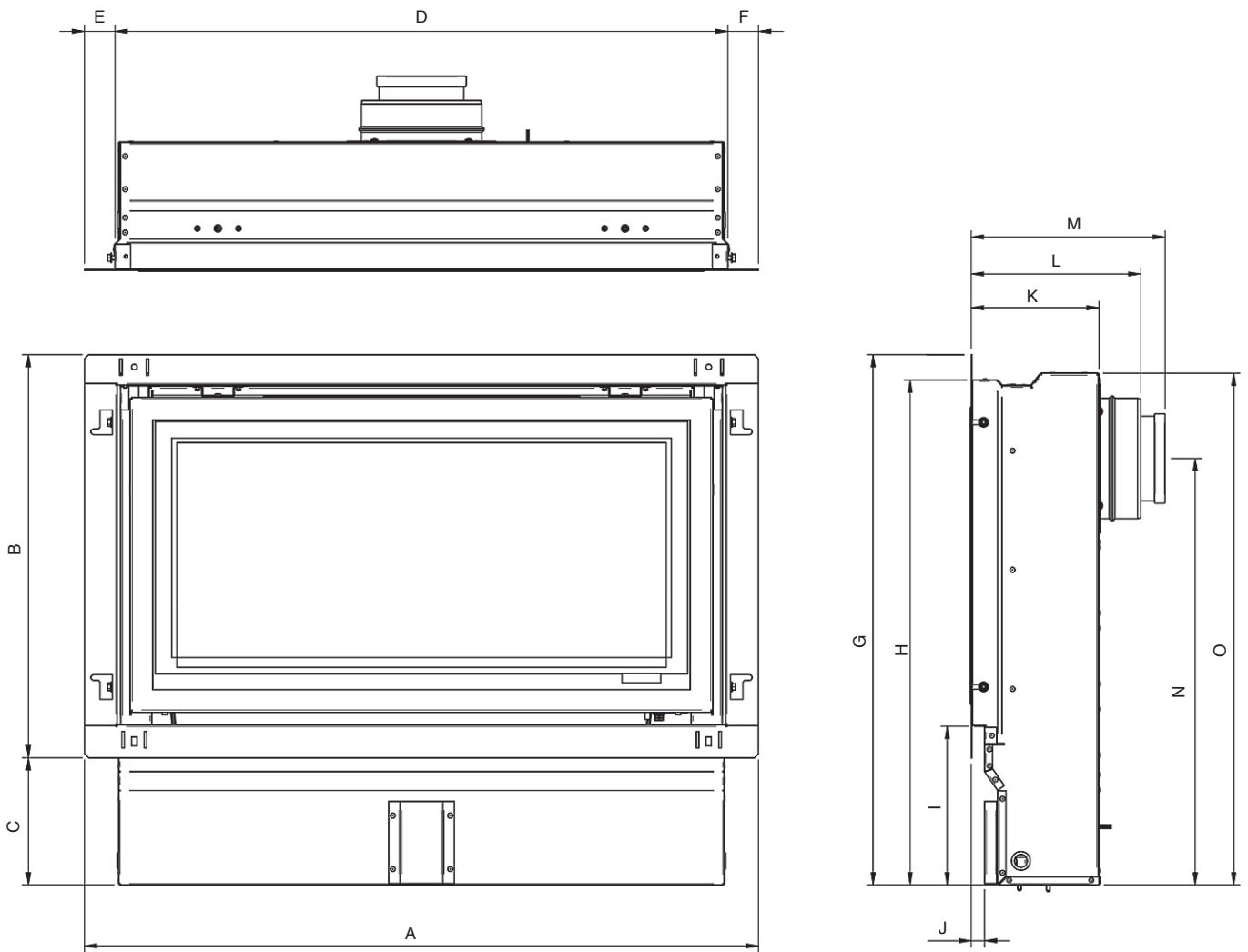

MODEL	A	B	C	D	E	F	G	H	I	J	K	L	M	N	O
Slimline 1	820	491	155	746	37	37	645	614	193	16	155	206	236	519	623
Slimline 2	1020	491	155	946	37	37	645	614	193	16	155	206	236	519	623

DIMENSIONS

Steel / Glass / Verve

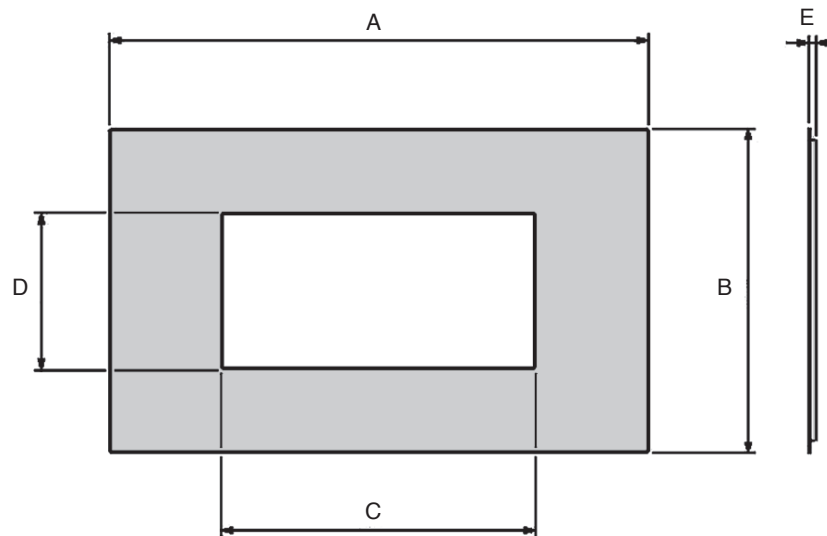

STEEL / GLASS / VERVE FRONTS

FRONT	A		B		C		D		E	
	STUDIO 1	STUDIO 2	STUDIO 1	STUDIO 2	STUDIO 1	STUDIO 2	STUDIO 1	STUDIO 2	STUDIO 1	STUDIO 2
Steel	1264	1500	528	528	646	846	320	320	27	27
Glass	1264	1500	528	528	650	852	324	324	29	29
Verve	1264	1500	528	528	650	850	324	324	53	53

Profil / Bauhaus / Expression

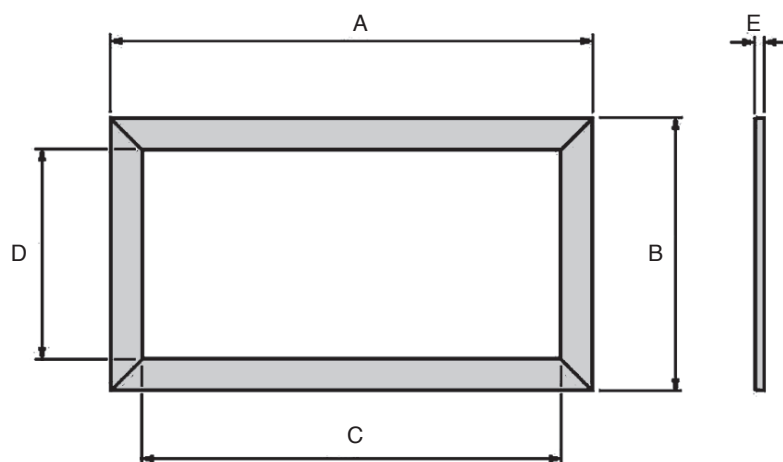

PROFIL / BAUHAUS EXPRESSION FRAMES

FRAME	A		B		C		D		E	
	STUDIO 1	STUDIO 2	STUDIO 1	STUDIO 2	STUDIO 1	STUDIO 2	STUDIO 1	STUDIO 2	STUDIO 1	STUDIO 2
Profil	836	1036	510	510	740	940	414	414	12.5	12.5
Bauhaus	850	1050	524	524	740	940	414	414	28	28
Expression	940	1140	614	614	740	940	414	414	40	40

INSTALLATION OF THE APPLIANCE

i **Note: This appliance has been designed to fit a masonry opening, however a studwork installation is possible if required.**

To open the glass door use the hexagon key provided.

Release the window locks by moving them from shut to open towards the outer edges, see Diagram.

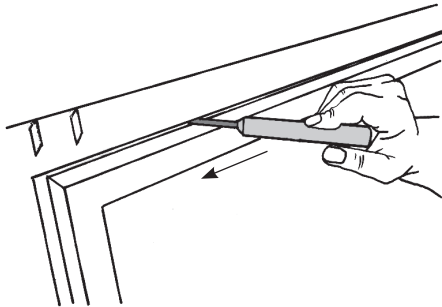

To completely remove the glass front:

Support the frame and lower it gently forward down to its natural stop position, see Diagram.

DO NOT EXERT PRESSURE ON THE DOOR ONCE THERE IS RESISTANCE.

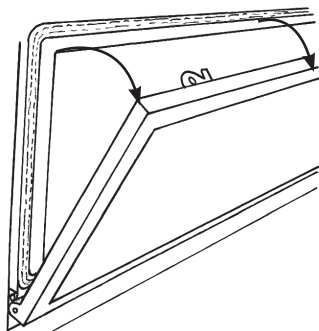

Remove the securing spring clip from the bottom-right of the window frame, see Diagram.

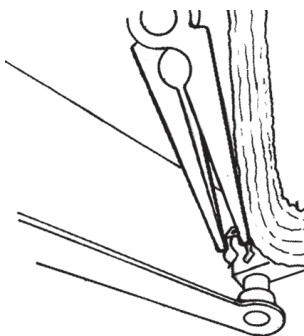

With the window frame in an upright position slide the frame to the left so that it comes off the left hinge pin, see Diagram.

Still keeping the frame upright drop the left side down and forward slightly, see Diagram.

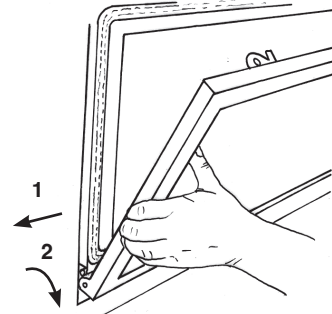

Slide the frame to the right so it comes off the **right** (all models) **and middle** (Studio 2 only) hinge pins. The window frame should now be free.

Place carefully to one side.

Refit the Window Frame Assembly in reverse order.

When closing the door ensure the door catches are fully engaged.



UNDER NO CIRCUMSTANCES SHOULD THE APPLIANCE BE USED WITHOUT THE CATCHES HOLDING THE DOOR IN PLACE.

Remove all the liners, see Replacing Parts.

Remove the Main Burner, see Replacing Parts.

Remove the Main Control Assembly, see Replacing Parts.

The gas supply enters the appliance through a silicon panel either on the floor or in the back panel under the access panel, see Diagram.

Studio 1 Slimline shown

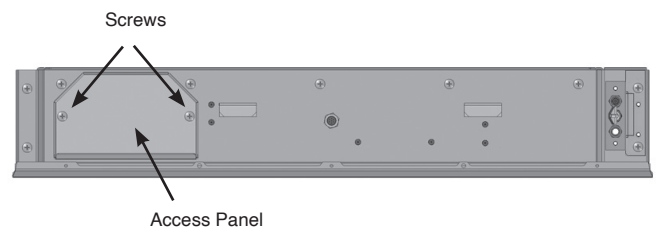

Slit with a sharp knife before bringing through the supply pipe.

REMOVAL OF THE SUBFRAME

For some installations it is necessary to remove the subframe before fitting the fire.

To remove the subframe prior to installation the four nuts securing it to the appliance must be loosened.

The nuts can be accessed from the side of the appliance or through the cut outs in the front of the subframe, see Diagram.

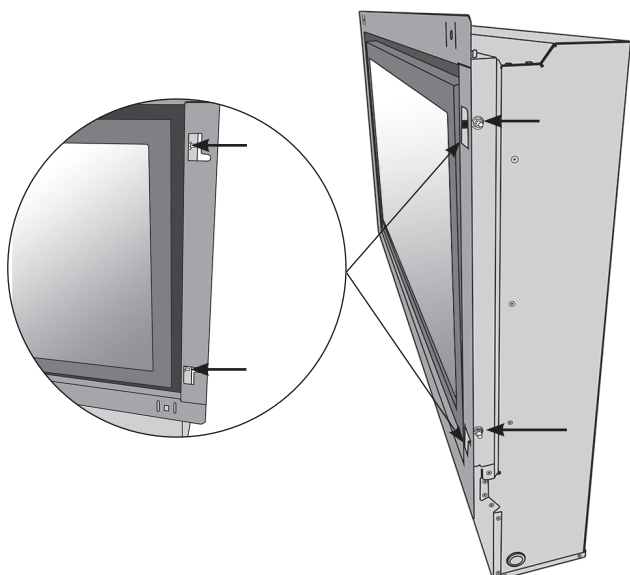

Loosen the nuts with a 8mm spanner but do not remove completely.

Pull the subframe forward to disengage from the channels, see Diagram.

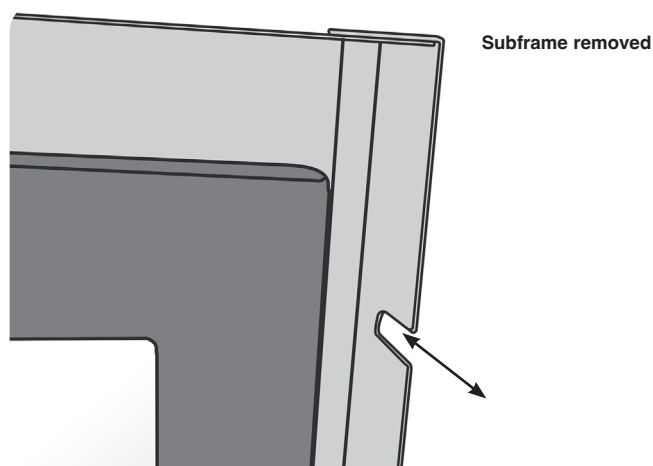

Replace in reverse order.

MASONRY INSTALLATION

This method of installation requires structural alteration to the intended location. A suitable supporting lintel must be installed to maintain the structural integrity of the surrounding blockwork.

There are three types of Masonry Installation:

1. Finishing with a Decorative Frame.

2. Using an Edge kit to create a flush finish.

Both these installations will require the same preparation and similar fitting methods. Carefully read and understand the relevant installation section before proceeding.

3. Installing the Studio Slimline into a Zero Clearance Box to reduce surface temperatures - see separate installation instructions (PR2268).

Mark the position of the lintel so that it sits centrally over the intended installation. Remove the blockwork and install the lintel using mortar to ensure a strong bond with the surrounding wall, see Diagram.

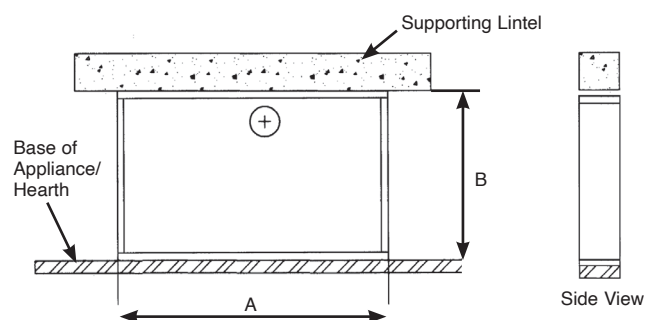

MODEL	STUDIO 1 SLIMLINE	STUDIO 2 SLIMLINE
A	780	980
B	655	655

With the lintel in position mark the width of the aperture and remove the blockwork.

Remove wall finish (eg plaster) from the area shown in the Diagram to the size of the appliance and minimum non-combustible clearances in all directions.

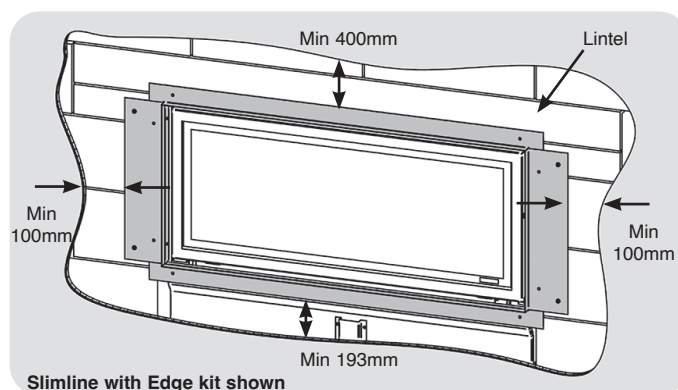

Ensure that there is a minimum of 10mm gap left between the back of the appliance and the outer wall. **There must be no combustible materials behind this appliance.**

Consider the final flue position ensuring that all required clearances are complied with, see Site Requirements.

Mark the position of the flue on the wall by measuring from the top of the finished hearth level/ base of the appliance, see Diagram.

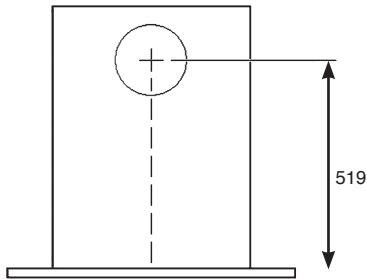

A 152mm (6") diameter hole is required to install the flue. This can be achieved by either:

- a) Core drill
- b) Hammer and chisel

It is advisable to drill small holes around the circumference when using method b. Make good both ends of the hole.

Line the sides, top and bottom of the opening with non-combustible board to prevent heat entering the cavity.

Prepare gas supply and cable.

If installing into a cavity, no joints should be within the cavity and the pipe must be sleeved. Refer to gas installation requirements.

Install the battery cable and wall plate box.

Gazco recommend that the cable is installed through conduit or similar to give protection and allow for future servicing.

When deciding the route of the cables consideration must be given to avoid contact with the appliance and the flue system.



IMPORTANT - Do not run the battery cable up the side of the appliance outer casing.

See relevant section for wall box and batteries installation.



The wall box must be installed using a non-metallic mounting box, please ensure that the plastic dry lining box is used where possible. For masonry installation it is possible to drill through the rear of the box and secure in position using wall plugs and screws although a small amount of finishing work will be required to cover the plastic side securing tags. Alternatively a standard 45mm (or greater) deep pattress box can be used to surface mount the wall plate.

FINISHING WITH A DECORATIVE FRAME - STEP 1

Position the appliance minus the subframe in the aperture, ensure that the appliance is level and that the front edge aligns with the proposed front face of the wall.

Mark the fixing holes in the base of the appliance.

Remove the appliance then drill and plug the holes.

Position the appliance in the aperture. It will be necessary to pass the gas supply pipe with the elbow through the silicone panel and the battery cable through the left or right hand rubber grommit.

Secure the appliance through the fixing holes in the base and check the appliance is level, see Diagram.

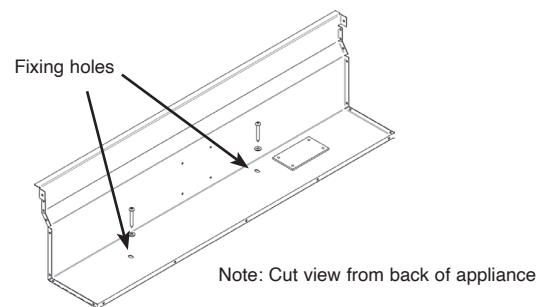

Proceed to Finishing Method A or B depending on how the wall is to be finished.

Note: the Decorative frame will require an additional step following the finishing of the wall.

CREATING AN EDGE FINISH



NOTE: WHEN INSTALLING THIS APPLIANCE USING THE 'EDGE' OPTION IT IS RECOMMENDED THAT THE WALL IS FINISHED WITH EITHER SLIPS OR TILES MANUFACTURED FROM STONE OR SIMILAR NATURAL MATERIALS. IF SUCH MATERIALS ARE USED IT IS RECOMMENDED THAT THEY ARE CUT INTO FOUR OR MORE SECTIONS TO PREVENT CRACKING.

RESIN BASED MATERIALS (EG MICRO MARBLE) ARE NOT USUALLY RECOMMENDED DUE TO THE EFFECT OF HEAT ON RESINS. HOWEVER THEY CAN BE USED IF THEY HAVE BEEN MANUFACTURED FOR USE AT ELEVATED TEMPERATURES WITHOUT PRODUCING ANY ODOURS OR STAINING.

There is an optional Studio Edge Installation Kit available for installing the appliance without a frame.

Using the installation kit:

With the sub-frame already secured to the appliance, fit the 4 metal brackets of the kit to the sub-frame and secure using the supplied fixings, see Diagram.

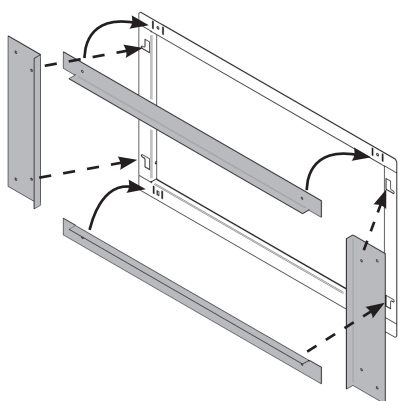

Fix foam seal to the rear of the outer flange of the appliance, see Diagram.

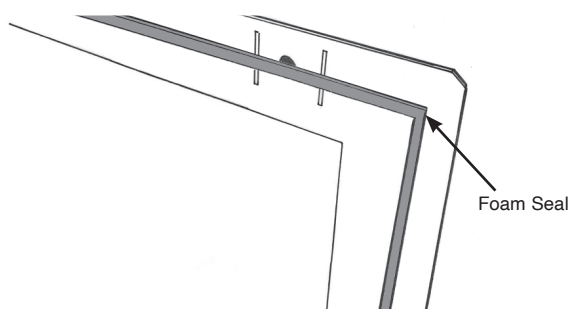

Secure the appliance to the wall through the holes in the Edge kit with the screws provided.

ALL INSTALLATIONS



IMPORTANT:

Once the appliance is in position there are 2 methods of finishing the wall.

A) Lining with heat resistant board which is then finished with a heat resistant plaster skim and decorated as required.

B) Reinstating the removed wall finish using a heat resistant render which is finished with a heat resistant plaster skim and decorated as required.

FINISHING METHOD A

Fit non-combustible board to the wall around the appliance. This should extend a minimum of 400mm above the appliance and 100mm at the sides, but ideally should cover a greater area to prevent cracking of the finished wall see Diagram.

Cut notches into the board to allow clearance for the subframe fixings.

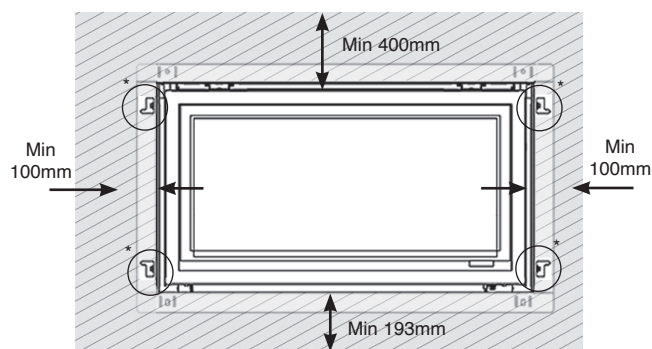

* Cut out notches

Fit plasterboard to the remaining chimney breast front.

After taking the normal steps to join the heat resistant board and plasterboard correctly, finish the whole area with a heat resistant plaster skim in the area directly around the appliance, see Diagrams.

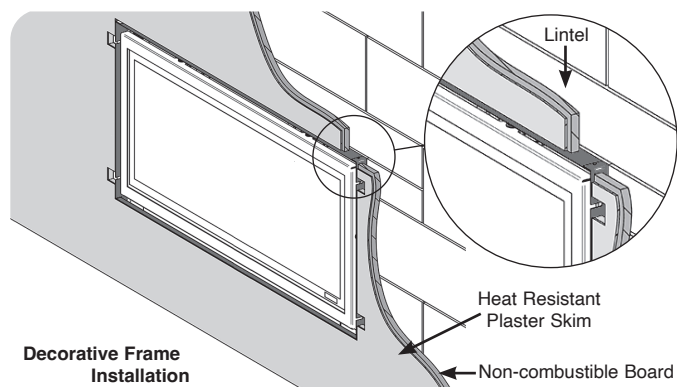

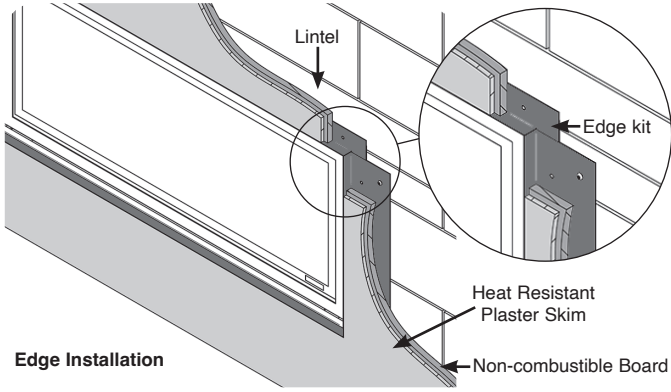

FINISHING WITH A DECORATIVE FRAME - STEP 2

Attach the 4 x frame fixing brackets to the sub-frame, see Diagram.

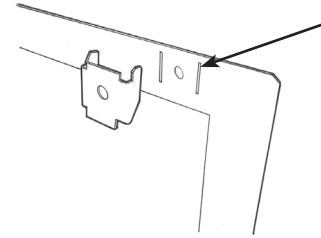

FINISHING METHOD B

Apply a render to the exposed wall using the Edge Frame as a guide. The render should finish 3-5mm shy of the finished wall face to allow for a final finish in Heat Resistant plaster skim to be applied.

Reinstate the remaining removed wall finish using a heat resistant render and finish with a heat resistant plaster skim.

Fix foam seal to the rear of the outer flange of the appliance, see Diagram.

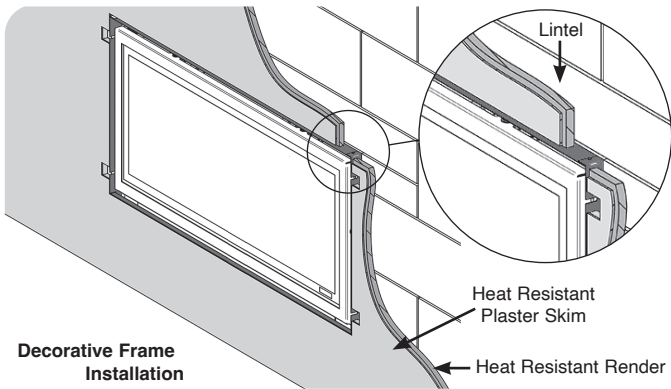
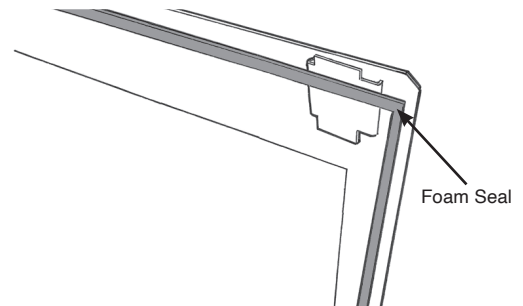

Fit the sub-frame to the appliance and ensure the returns of the sub-frame fit internally into the main outer box with the studs and securing nuts passing through the side slots. Secure by tightening the 4 nuts, see Diagram.

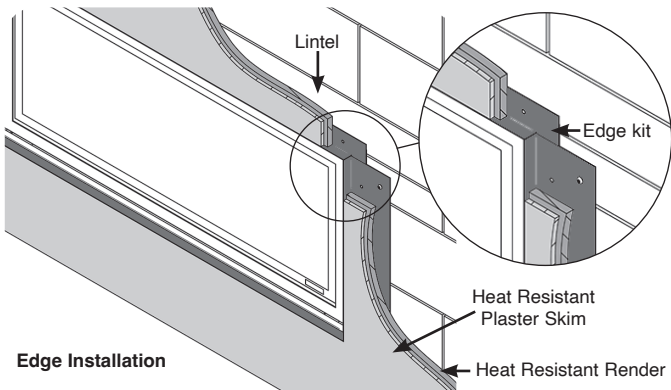
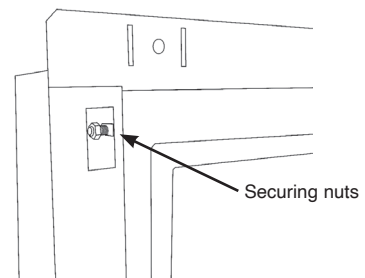

Secure the appliance and sub-frame to wall through the holes in the sub-frame with the screws provided.

Decorate as required.

Note: There are no more steps required for a seamless Edge finish.

If the finished wall does not line up with the top fixing holes in the sub-frame then the side holes can be used to fix the frame back to the wall. However, the frame fixing brackets **must** be fixed to the sub-frame.

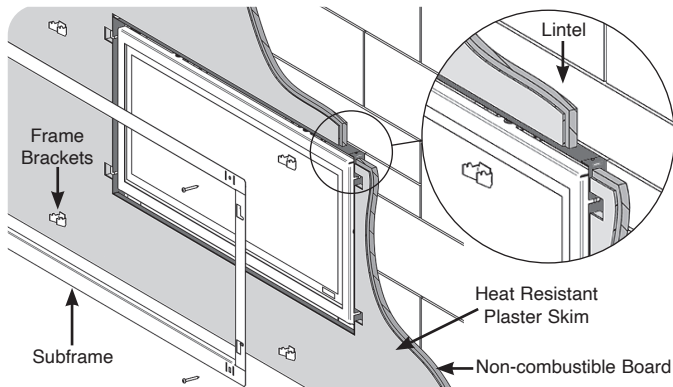

Screw the lower frame fixings through the sub-frame at the base of the appliance.

Fit the decorative front referring to individual installation instructions.

STUDWORK INSTALLATION

THERE ARE THREE TYPES OF INSTALLATION INTO STUDWORK DESCRIBED IN THE FOLLOWING PAGES:

- 1) FOR STUDIO SLIMLINE WITH DECORATIVE FRONT (SEE STUDWORK INSTALLATION FOR STUDIO WITH FRAMES).
- 2) FOR AN INSTALLATION WHERE THE STUDIO SLIMLINE SITS FLUSH TO THE FINISHED 'EDGE' OF THE WALL (SEE STUDWORK FOR EDGE INSTALLATION KIT).
- 3) FOR A FURTHER 'EDGE' INSTALLATION PROVIDING A COOL WALL ABOVE THE APPLIANCE TO ALLOW CUSTOMERS TO HANG PICTURES ETC. (SEE STUDWORK FOR COOL WALL INSTALLATION KIT).

i IMPORTANT: NEVER position a television or screen above this appliance.

DISTANCE TO COMBUSTIBLE MATERIAL

COMBUSTIBLE PARTS OF THE STUDWORK MUST BE KEPT BEYOND THE MINIMUM DIMENSIONS SHOWN IN DIAGRAM. EVEN IF THE FRAMEWORK IS PROTECTED BY NON-COMBUSTIBLE MATERIAL, YOU MUST MAINTAIN THESE DIMENSIONS, SEE DIAGRAM.

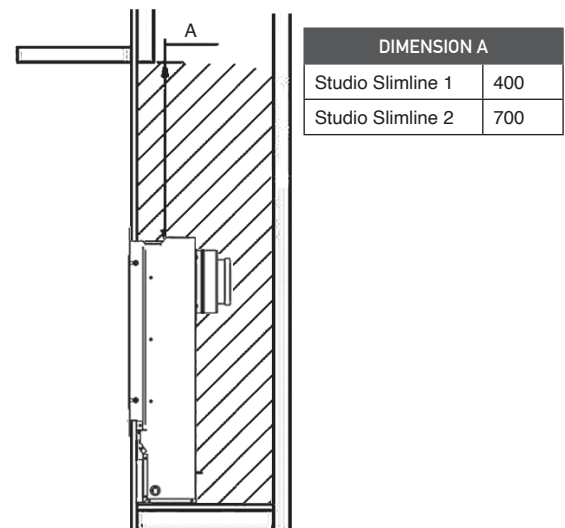
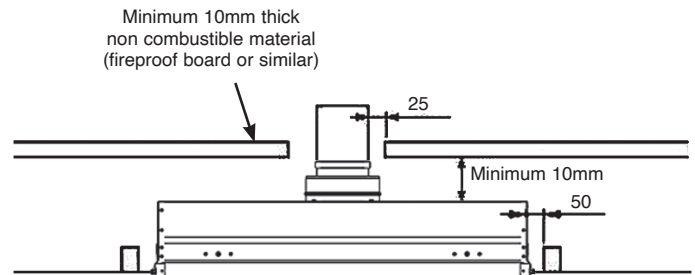

DO NOT PACK THE VOID AROUND OR ABOVE THE APPLIANCE WITH INSULATION MATERIALS SUCH AS MINERAL WOOL.

THE VOID BUILT FOR THE CASSETTE MUST BE VENTILATED TO PREVENT A BUILD-UP OF HEAT. IF THE VOID IS SEALED, THEN YOU MUST FIT VENTS AT BOTH LOW AND HIGH LEVELS OF APPROXIMATELY 50CM² EACH. THESE VENTS MUST TAKE COLD AIR FROM THE ROOM AND RETURN WARM AIR BACK INTO THE ROOM.

AN ACCESS HATCH MUST BE LEFT IN THE SIDE OF THE CHIMNEY BREAST FOR FUTURE SERVICING AND INSPECTION OF THE FLUE AND APPLIANCE.

STUDWORK INSTALLATION FOR STUDIO WITH FRAMES

Build the studwork chimney breast and enclosures to the desired size to include the protected platform at the required height.

Line the aperture for the appliance with 12mm thick non-combustible material as shown.

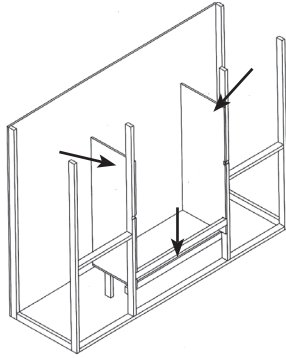

Ensure the clearances are maintained, see Diagram.

Site the appliance and decide on flue requirements.

Cut a hole for the flue exit, see Installation Instructions.

Provide gas services into the cassette void on the left-hand side.

Because no combustible material can be used above the appliance, Gazco provide a support bar.

Mark out the position to fit the supplied top support bar into the studwork at the correct height.

This bar needs to be recessed into the studwork, see Diagram.

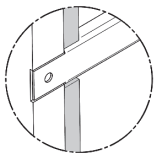

Detail A

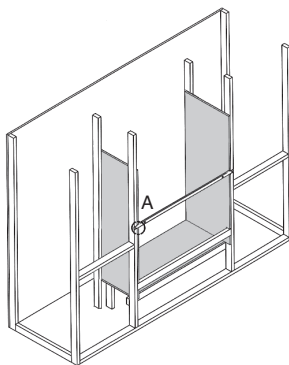

Fit the support bar into the studwork at the correct height, see Diagram.

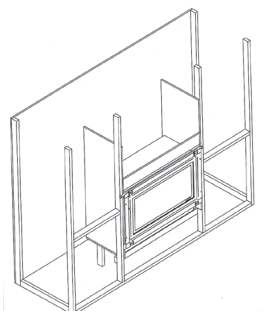

Position the appliance in the aperture, ensure that the appliance is level and that the front edge aligns with the proposed front edge of the wall.

Secure the appliance to the base of the studwork plinth using the fixing screws supplied, see Diagram.

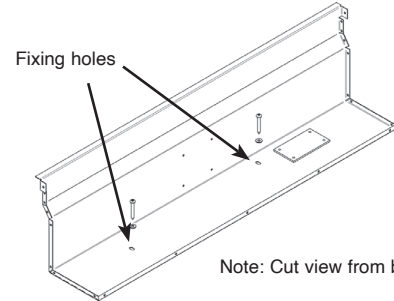

Note: Cut view from back of appliance

Fit non-combustible board to the studwork around the appliance. This should extend a minimum of 400mm above and at least 100mm to the sides of the appliance, leaving a minimum of 15mm gap either side of the appliance to allow clearance for the sub frame fixings, see Diagram.

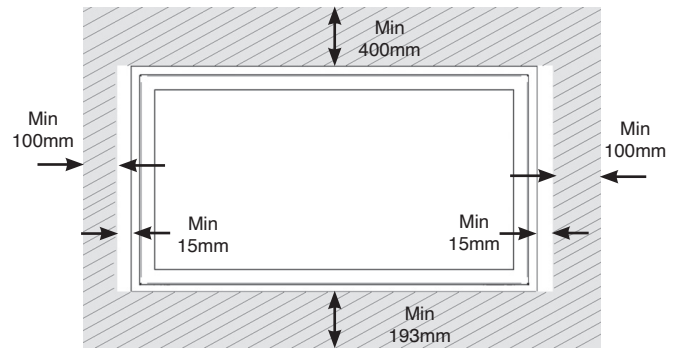

Apply plasterboard to the remainder of the studwork.

Apply a plaster finish to the front of the chimney breast, ensuring that heat resistant plaster is used in the areas shown in Diagram.

Attach the 4 x frame fixing brackets to the sub-frame, see Diagram.

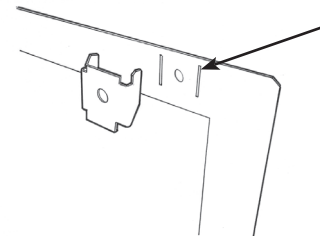

Fix foam seal to the rear of the outer flange of the appliance, see Diagram.

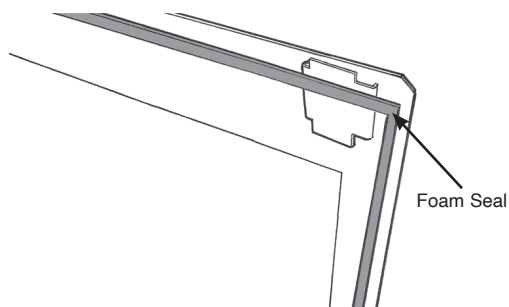

Fit the sub-frame to the appliance and ensure the returns of the sub-frame fit internally into the main outer box with the studs and securing nuts passing through the side slots. Secure by tightening the 4 nuts, see Diagram.

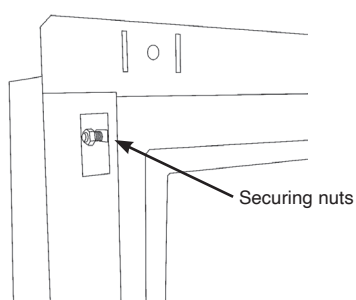

Secure the appliance to the studwork using four screws through flange, bracket and support bar.

SLIPS

Because of the high temperatures this appliance achieves, it is advisable to use marble slips or similar material between the appliance and the plasterboard.

Never use a one-piece slip as expansion (even cracking) can occur.

Note: If a slip is used, longer screws are needed to secure the appliance.

To finish this installation:

Connect the wall box and batteries following the instructions in - All types of Installation Wall Box & Batteries.

Connect:

- The flue system, see Installation, Flue Assembly.
- Gas services, see Installation of the Appliance, using the opening in the side of the chimney breast for access.

After commissioning:

Finish the sides of the chimney breast, see Diagram.

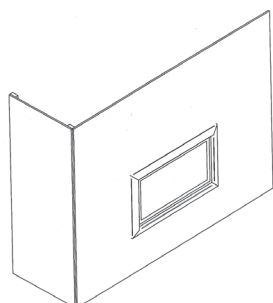

STUDWORK FOR EDGE INSTALLATION KIT

There is an optional Studio Edge Installation Kit available for installing the appliance without a frame: Studio Code No. 8727BF EK01.

Using the installation kit:

Fit the four metal brackets of the kit to the sub-frame, see Diagram.

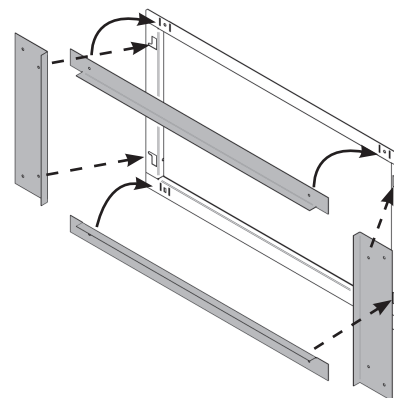

Fix foam seal to the rear of the outer flange of the appliance, see Diagram.

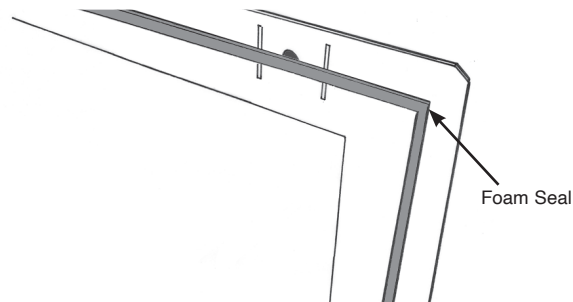

Fit the sub-frame to the appliance and ensure the returns of the sub-frame fit internally into the main outer box with the studs and securing nuts passing through the side slots. Secure by tightening the 4 nuts, see Diagram.

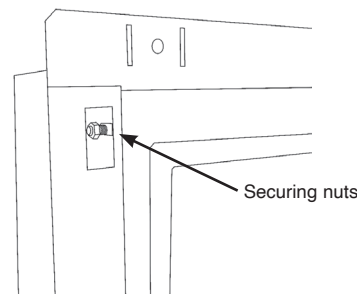

Build the studwork chimney breast to the desired size.

Ensure all clearances to combustible material are maintained, see Studwork Installation

Put vertical studwork at minimum clearance to the side of the appliance (50mm).

Decide on flue requirements.

Cut a hole for the flue exit, see Installation Instructions.

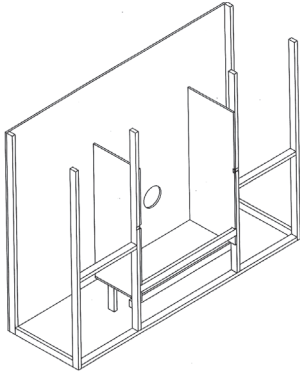

Secure to the vertical studwork through the holes in the metal brackets fitted to the appliance.

The kit has been designed so that non-combustible board can be taken right up to the edge of the four brackets, see Diagrams.

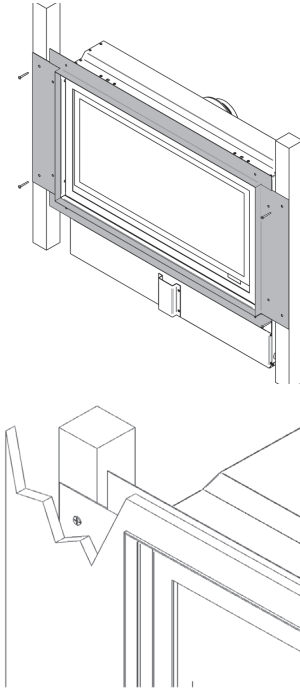

Fit non-combustible board to the studwork above the appliance. This should extend a minimum of 400mm above the appliance and 100mm to the sides, see Diagram.

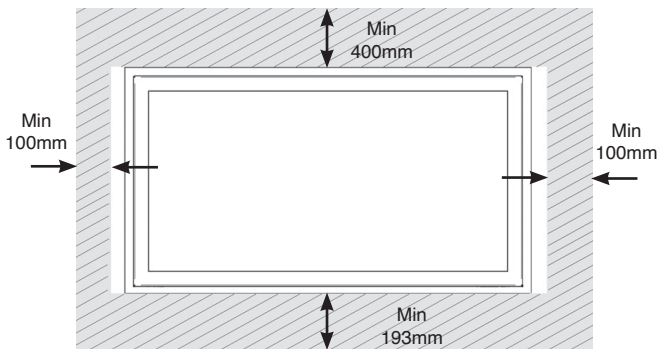

Fit plasterboard to the remaining chimney breast front.

Connect the flue system and gas services using the opening in the side of the chimney breast for access.

After commissioning, finish the sides of the chimney breast, see Diagram.

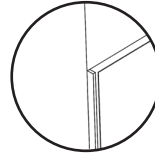

Detail A

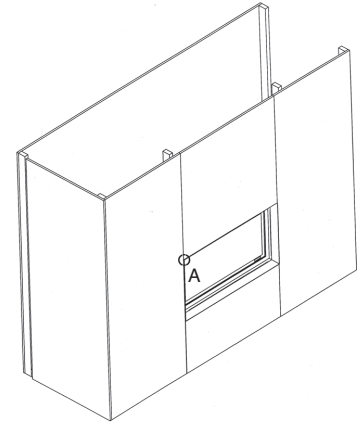

Apply a plaster finish to the chimney breast using heat resistant plaster in the area directly around the appliance, see Diagram.

STUDWORK FOR COOL WALL INSTALLATION KIT

For this cool-wall installation, the convected heat produced by the appliance is channelled into the chimney cavity and vented at the top.

The cool wall installation kit is provided unfinished. This allows the kit to be finished to match the front face decor.

There is an optional Studio Cool Wall Installation Kit available for installing the appliance without a frame.

Using the fixing kit:

Fit the four metal brackets of the kit to the sub-frame, see Diagram. There is a deliberate gap at the top for convected heat.

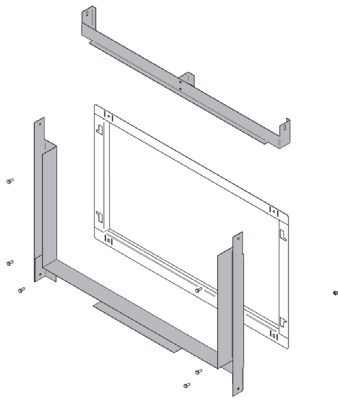

Fit the sub-frame to the appliance and ensure the returns of the sub-frame fit internally into the main outer box with the studs and securing nuts passing through the side slots. Secure by tightening the 4 nuts, see Diagram.

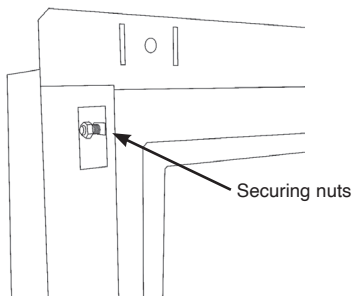

This now determines the width of your two vertical studwork supports. The kit has been designed so that non-combustible board can be taken right up to the edge of the four brackets, see Diagrams.

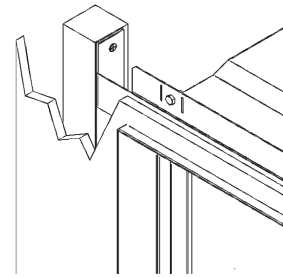
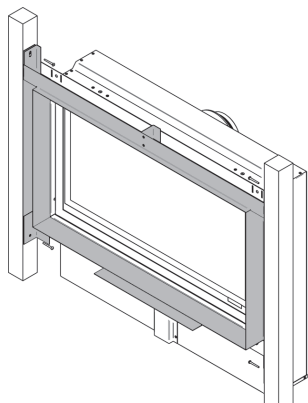

Fix the left and right metal brackets into the studwork
Build the studwork chimney breast to the desired size.

Ensure all clearances to combustible material are maintained, see Studwork installation.

Decide on flue requirements.

Cut a hole for the flue exit, see Installation Instructions.

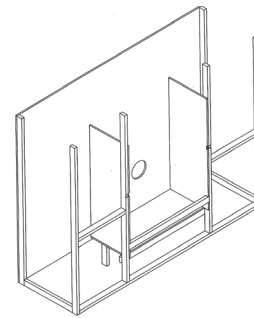

Fit non-combustible board to the studwork above the appliance. This should extend a minimum of 400mm above the appliance and 100mm to the sides, see Diagram.

Fit plasterboard to the remaining chimney breast front.

Connect the flue system and gas services using the opening in the side of the chimney breast for access.

After commissioning, finish the sides of the chimney breast, see Diagram.

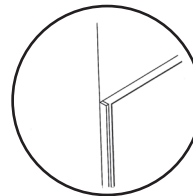

Detail A

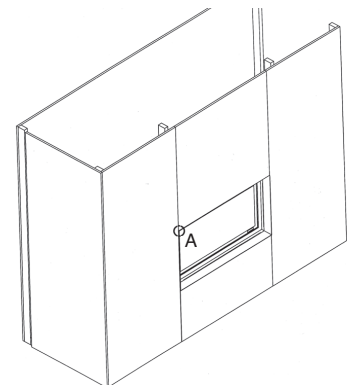

The top of the chimney breast must have a minimum 200cm² vent.

Apply a plaster finish to the chimney breast using heat resistant plaster in the area directly around the appliance, see Diagram.

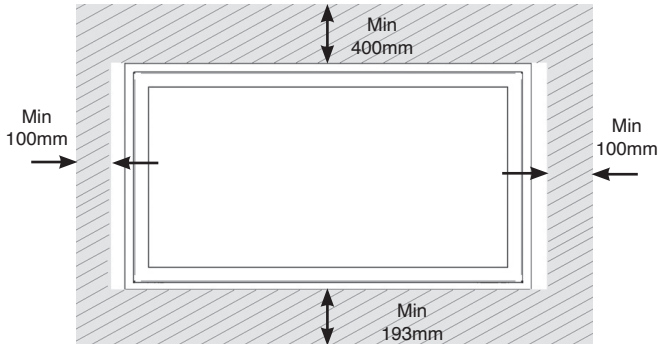

FLUE ASSEMBLY

FLUE LENGTH:

- MIN = 90mm
- MAX = 660mm

Unpack the flue assembly and terminal guard.

Do not lose the fixings.

Consider the final appliance position ensuring you comply with clearances required for the external flue, see Site Requirements..

Mark the vertical centre-line of the appliance on the wall, see Diagram, A.

Mark the height from the base of appliance to the centre of the flue, see Diagram, B.

TAKE CARE TO MARK OUT THE FLUE CORRECTLY. IT IS DIFFICULT TO MOVE AFTER INSTALLATION.

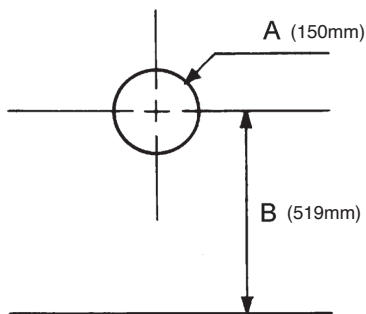

FLUE LENGTH

With the appliance secured in place, (minimum 10mm gap between the back of appliance and the wall) measure the distance from the back of the appliance to the outside face of the wall. Deduct 18mm from this measurement.

Insert the square cardboard sleeve into the flue to support the inner tube.

Cut through the flue and sleeve, see Diagram.

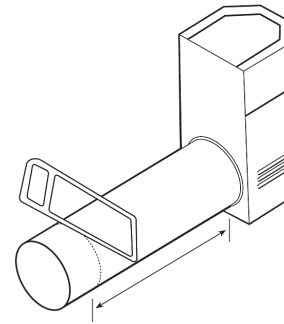

REMOVE THE CARDBOARD REMNANTS FROM THE FLUE.

File the cut edges smooth.

TERMINAL

On the outside wall:

Position the flue assembly into the hole. The terminal should be flat against the wall.

Make sure the terminal is vertical, see previous Diagram.

Mark the 4 fixing holes.

Remove the terminal to drill the holes.

Insert wall plugs supplied.

DO NOT FIX THE FLUE AT THIS STAGE.

FLUE AND APPLIANCE FIXINGS

Position the appliance observing appropriate clearances.

Apply a bead of suitable weatherproof sealant (silicone or similar) to perimeter of back face of terminal, see Diagram.

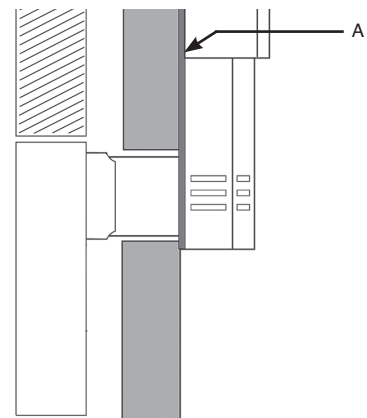

Feed the flue through the wall, making sure it runs smoothly.

Engage the flue in the inner and outer spigots.

Make sure rubber seal on the spigot is not damaged, it may be necessary to lubricate the seals with washing up liquid (or similar) to ease assembly.

i To ensure a successful installation take out the baffle plate by removing the 8 fixing screws, see first Diagram.
 It is now possible to view if the end of the flue is located correctly, see second Diagram.
Note: Studio 1 Slimline shown in diagram but fixing points are the same for all models.

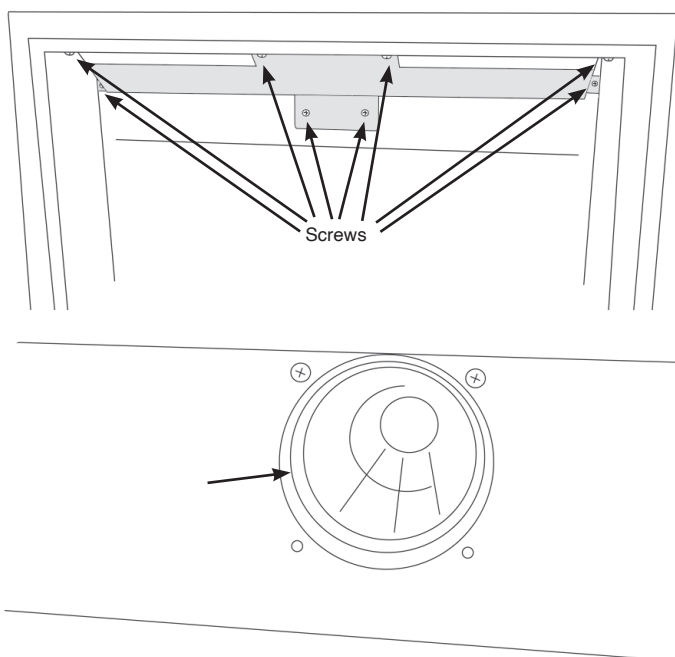

Insert 4 screws in the flanges of the flue terminal.

Check sealant has formed a water-tight joint to the wall.

Any terminal less than 2m above any access (level ground, balcony or flat roof with access) must be fitted with the guard supplied, see Diagram.

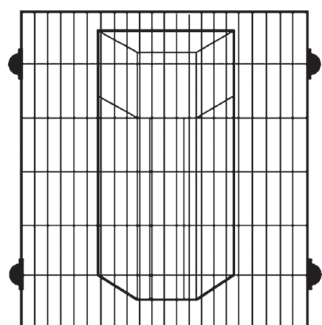

ALL TYPES OF INSTALLATION - WALL BOX & BATTERIES



Please note: As an optional extra Gazco can provide a mains adapter to supply constant power to the appliance control box instead of the battery pack.

If installing an appliance with the adapter make provision for a mains power socket within 1.5m of the control box and follow the instructions provided.

When installing the wall box allow at least 100mm of slack wire in the battery lead where it enters the appliance on the right hand side. This allows the removal of the control assembly during servicing.

Decide on the position for the wall box containing the batteries and wall plate and cut the necessary hole.

A battery power supply cable is supplied and pre-fitted to the appliance control. Provision is made for the cable to exit either the left or right of the appliance through the grommet. The cable is 3 metres long.

Connect the wire from the appliance to the battery pack, see Diagram.

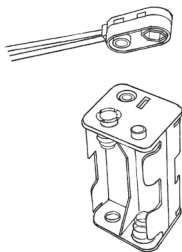

Correctly position the four new AA size batteries and re-assemble the battery holder as shown, see Diagram.

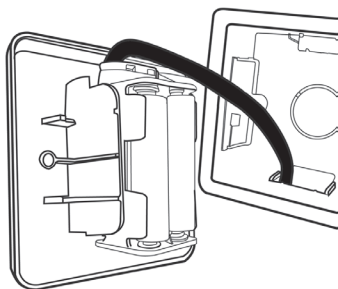

Secure the wall plate to the wall box using the two fixing screws, see Diagram

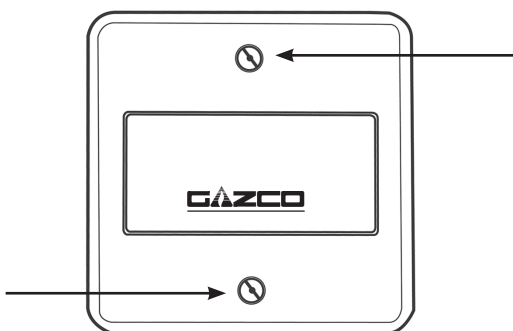

IMPORTANT

The wall plate must be installed using a non-metallic mounting box, please ensure that the plastic dry lining box is used wherever possible. If it is intended to install the wall plate into masonry it is possible to drill through the rear of this box and secure in position using wall plugs and screws although a small amount of finishing work will be required to cover the plastic side securing tags. Alternatively a standard 47mm deep pattress box can be used to surface mount the wall plate.

PLEASE ENSURE NO WIRES ARE TRAPPED BEFORE REPLACING THE WALL PLATE. THE LEAD IS EASILY DAMAGED.

ASSEMBLING THE APPLIANCE

LINERS

The Slimline Studio appliance has the option of 4 different liner finishes:

- Vermiculite
- Black Reeded
- Brick Effect
- Black Glass Linings - see separate instructions for fitting.

There are two clips at the top of the firebox that are used to secure the back panel in position. These must be removed before fitting the liners, see Diagram.

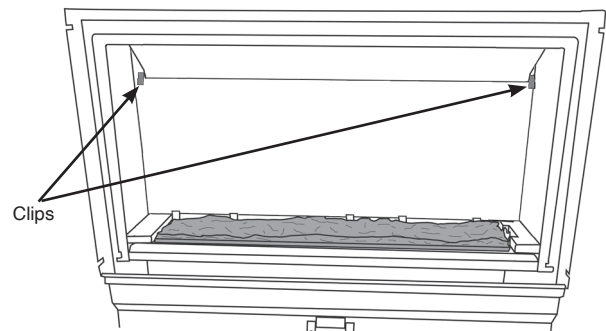

Place the Bottom Side Liners against the side and back of the firebox, then fit back liner panel into position against the back of the appliance, see Diagram.

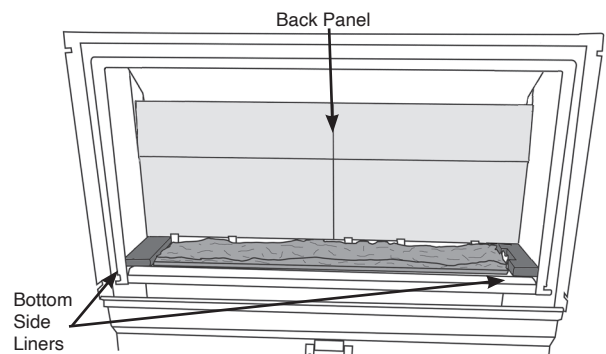

Reattach the two clips to hold the back panel in place, see Diagram.

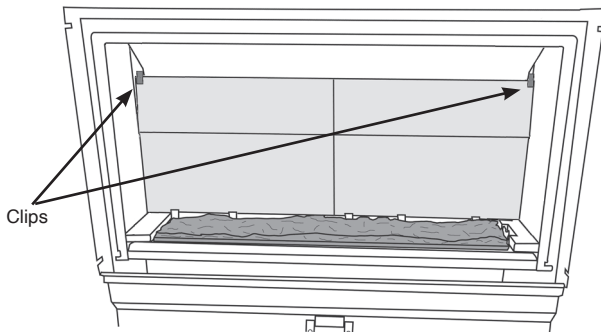

Slide the two side liners into place to finish, see Diagram.

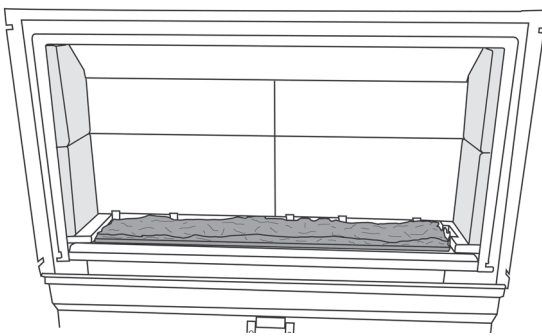

Removal of the liners is the reverse of this process.

ARRANGEMENT OF THE FUEL BED

ADVICE ON HANDLING AND DISPOSAL OF FIRE CERAMICS



BLACK REED AND BRICK EFFECT LINERS

These lining panel options are available for this product and contains Refractory Ceramic Fibre (RCF), a material which is commonly used for this application.

RCF waste is classed as stable, non-reactive hazardous waste and may be disposed of at a licensed landfill site.

If replacing these items do not break them up. Seal within heavy duty polythene bags and label as RCF waste.

Protective clothing is not required when handling these articles.

If the Liners are visibly broken Gazco recommend using gloves and a face mask to remove the pieces and remove any dust accumulated in and around the appliance before and after working on it with a HEPA filtered vacuum.

If any concerns remain contact Gazco Technical Customer Services to obtain the manufacturers COSHH Data Sheet.

LOG LAYOUT

LOGS MUST BE POSITIONED ACCORDING TO THE FOLLOWING INSTRUCTIONS TO GIVE THE CORRECT FLAME EFFECT.

STUDIO 1 LAYOUT

Ensure the burner tray is clean and free from any debris.

All logs can be identified by a letter (A - D) on their underside.

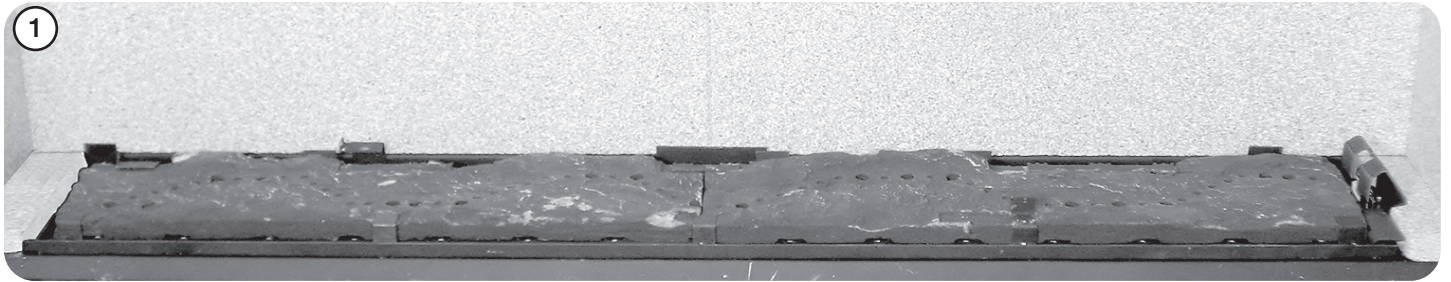

Position Log A between the two tabs at the back of the burner tray, see Diagram 2. The left hand side should rest on the tab at the back of the burner tray and be pushed up to the supporting lip, see Diagram 2 Detail.

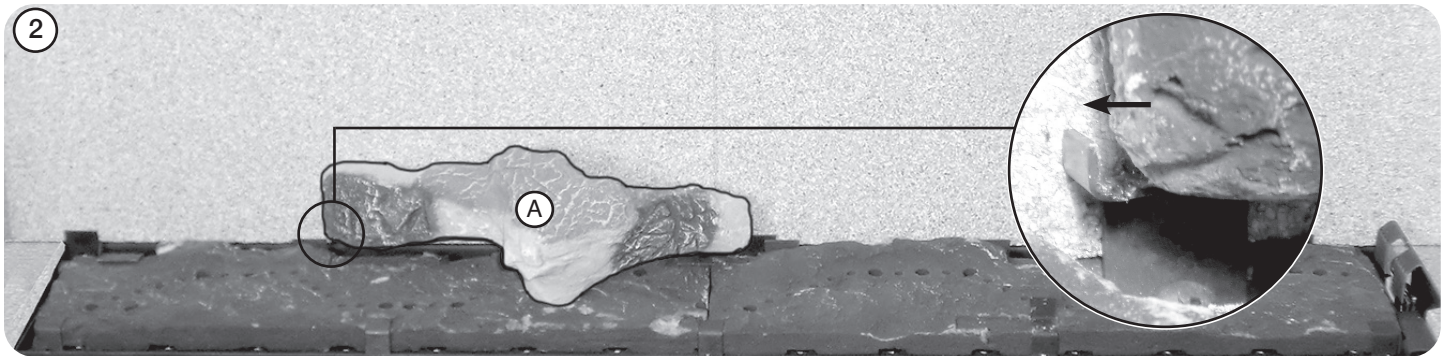

Place the left hand end of Log B against the back right tab on the burner tray, see Diagram 3. Ensure that the front branch is in line with the front of the burner tray.

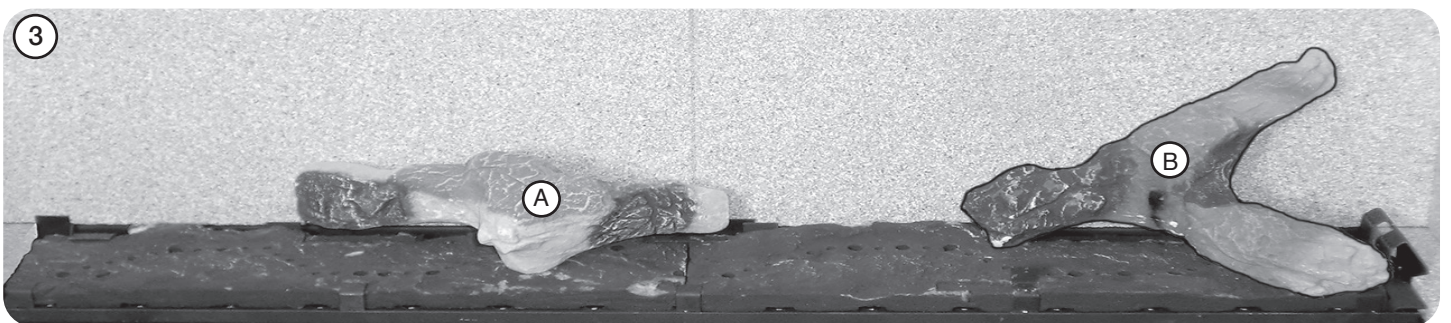

Rest the left end of Log C on the bottom left vermiculite panel in the back left corner, see Diagram 4.
The right end of Log C rests across Log A with the small front branch resting on the burner tray.

Engage the left hand end of Log D with the right hand end of Log A.
The right hand end of Log D fits in front of the metal stop on the front of the burner tray.

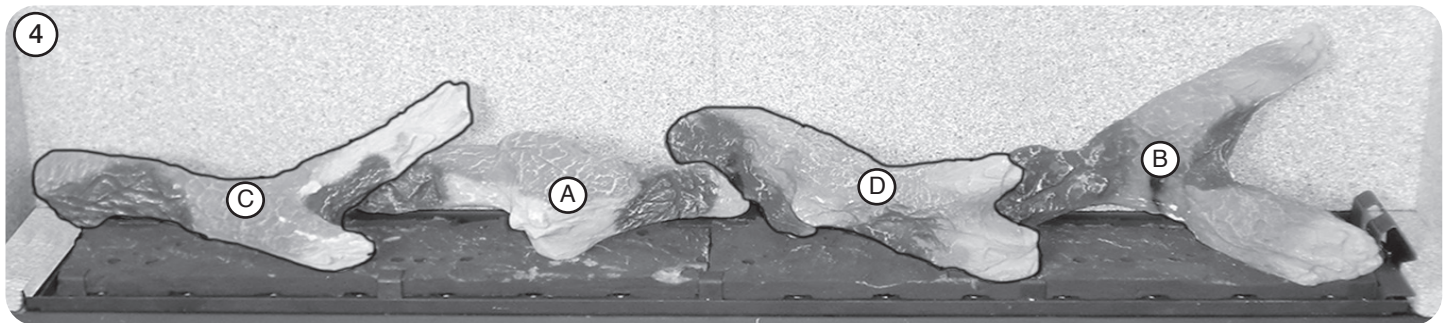

Separate the Embaglow material into smaller pieces and pull into shape to create a fine layer.

Sparingly spread an amount of the Embaglow fibres provided, covering the ports in the burner tray, see Diagram 5.
Ensure the material is placed loosely to create a random glow.
Take care not to use more than half a packet per application.

WARNING - DO NOT PLACE NEAR THE PILOT AREA.



STUDIO 2 LAYOUT

Ensure the burner tray is clean and free from any debris.

All logs can be identified by a letter (A , B, C, 2 x D, E) on their underside.

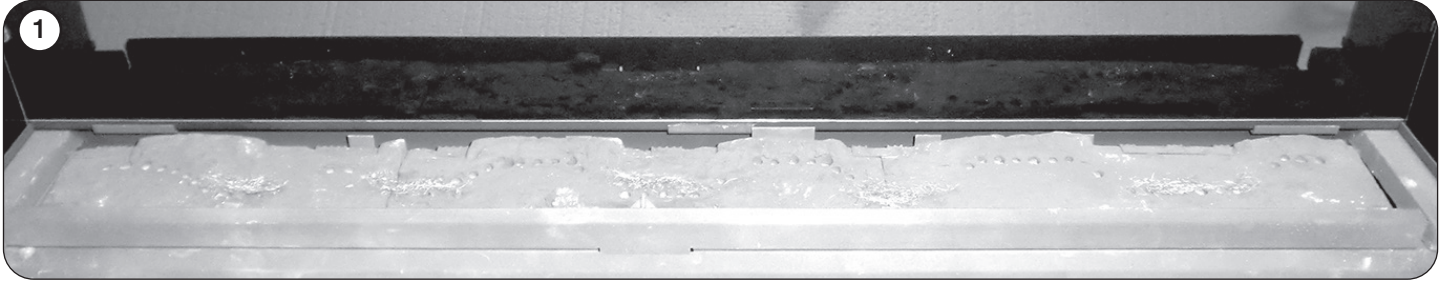

Position Log A between the two tabs at the back of the burner tray, see Diagram 2. Ensure that it is pushed up against the back panel and the end of Log A is on the raised section of the burner.

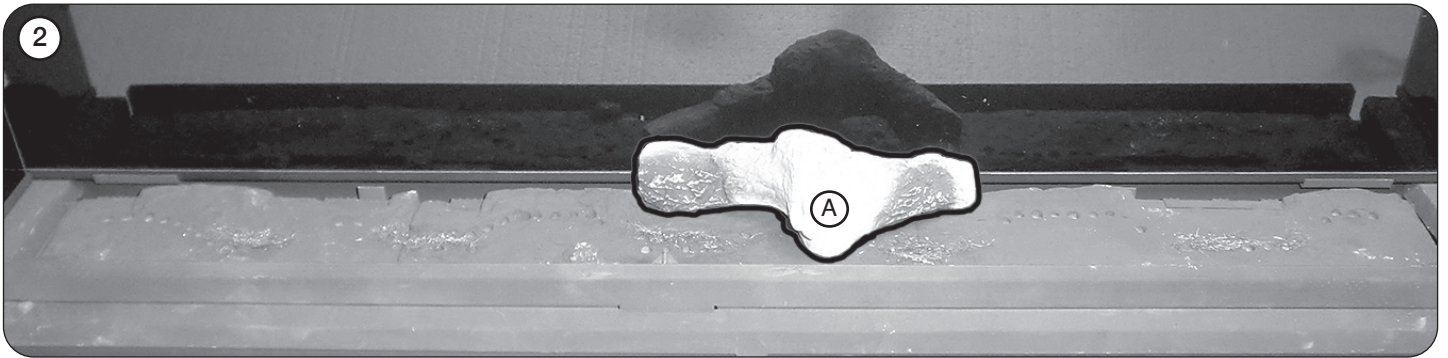

Place the left hand end of Log B against the back right tab on the burner tray, see Diagram 3. Ensure that the front branch is in line with the front of the burner tray.

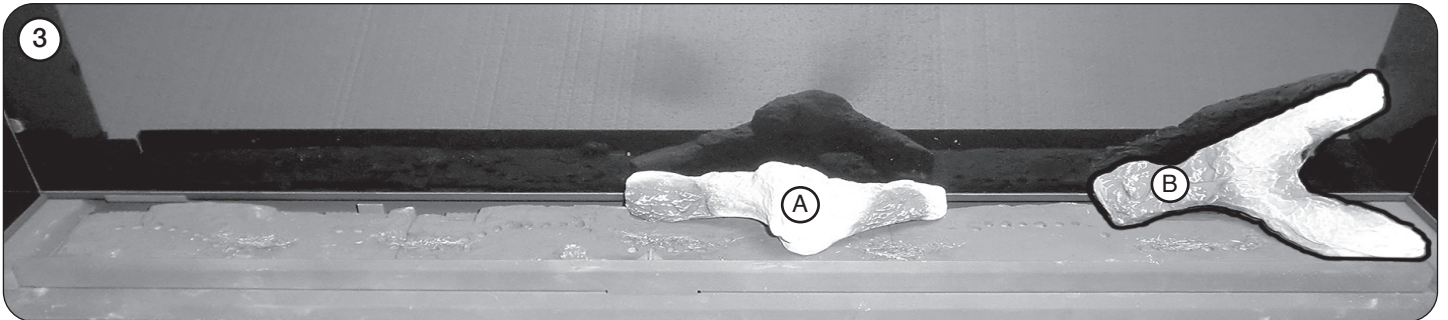

12.13 Rest the left end of Log D on the bottom left vermiculite pane, see Diagram 4. The right end of Log D should be touching the rear liner.

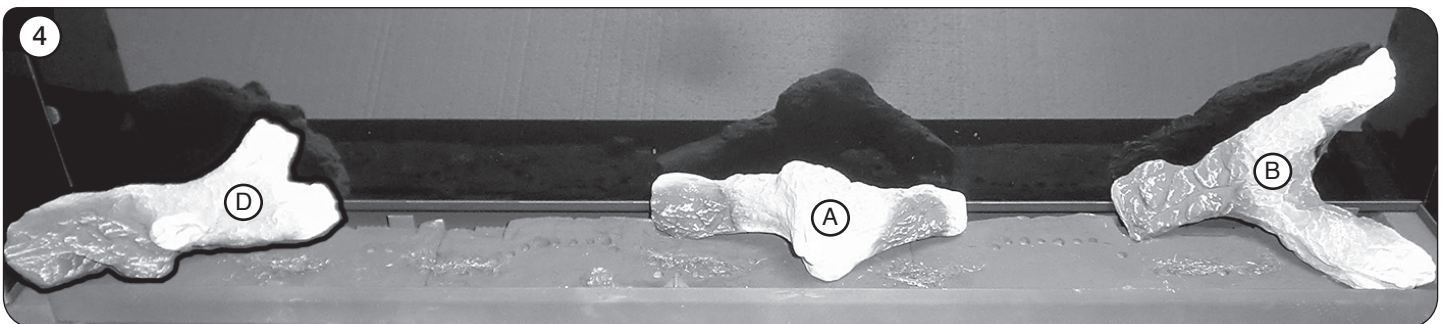

Engage the left hand end of Log D with the right hand end of Log A.
The right hand end of Log D fits in front of the metal stop on the front of the burner tray.

Place the left hand side of Log C to the rear of the burner tray against the tab and the right hand side at the front of the burner with the rear section resting on Log A.

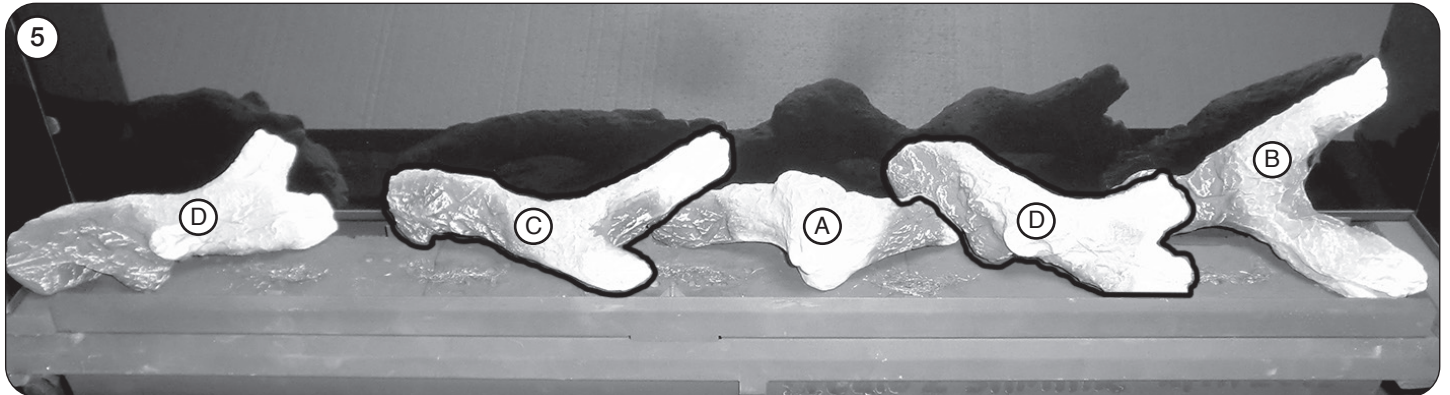

Log E rests against logs C and D with the lower end located in the cutout in the burner, see Diagram 6.

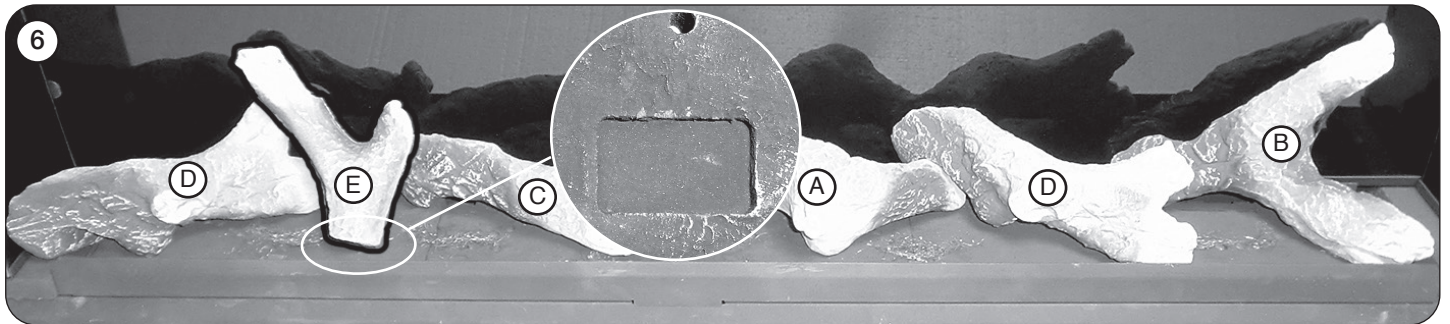

Separate the Embaglow material into smaller pieces and pull into shape to create a fine layer.

Springly spread an amount of the Embaglow fibres provided, covering the ports in the burner tray, see Diagram 70.
Ensure the material is placed loosely to create a random glow.
Take care not to use more than half a packet per application.

WARNING - DO NOT PLACE NEAR THE PILOT AREA.



STONE / GLASS FUEL EFFECT LAYOUT

To use the white stone or glass granule fuel effect, apply according to the following instructions to give the correct flame effect.

Ensure the burner tray is clean and free from any debris, see Diagram 1.

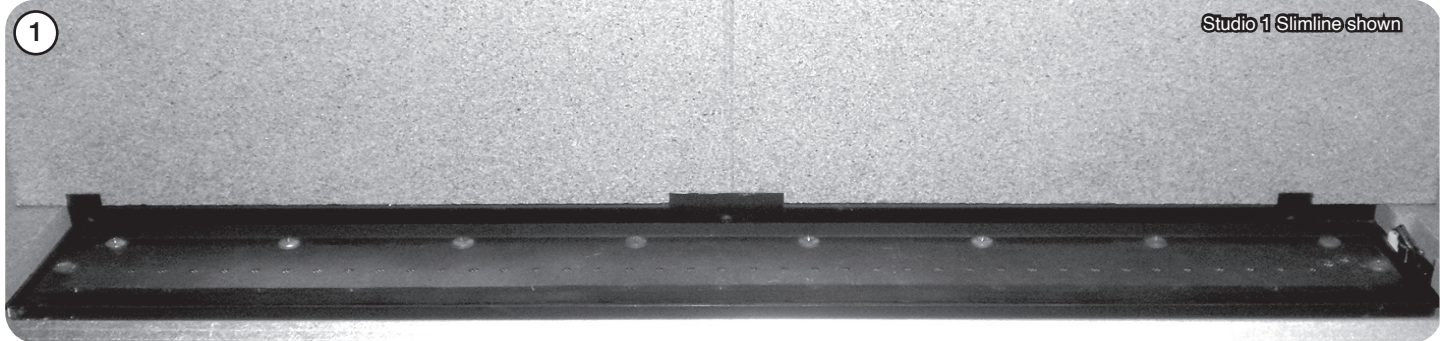

Fill the tray making sure the effect is flattened so it is level with the rim of the tray.
DO NOT OVERFILL THE BURNER TRAY.

TAKE CARE NOT TO SPILL EFFECT INTO THE PILOT AREA FRONT CHANNEL OR GAP AT REAR OF TRAY see Diagram 2.

ONLY GENUINE GAZCO PARTS CAN BE USED IN THIS APPLIANCE.



COMPLETION OF ASSEMBLY

To fit the window frame keep the frame in the upright position with the locks uppermost.

Offer the frame to the foot of the opening.

Slide the frame to the right to locate the right hinge pin.

Manoeuvre the frame up towards the left side to locate the middle (**Studio 2 only**) and left hinge pins (**Studio 1 and 2**).

Slide onto the hinge with a right movement.

Secure in place with a spring clip at the right hinge pin, see Diagram.

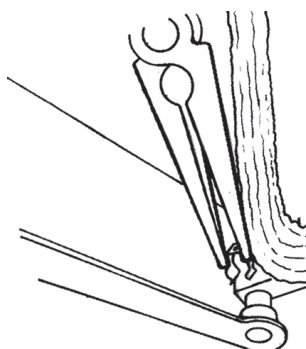

Close the window.

Using the hexagon key provided close the window locks by moving from open to shut towards the window centre, see Diagram.

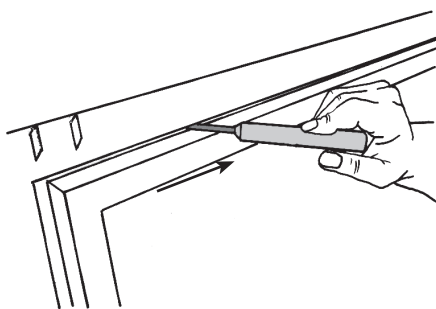

When closing the door ensure the door catches are fully engaged.



UNDER NO CIRCUMSTANCES SHOULD THE APPLIANCE BE USED WITHOUT THE CATCHES HOLDING THE DOOR IN PLACE.

LIGHTING THE APPLIANCE

The appliance is operated by thermostatic remote control.



This remote controls the appliance from pilot ignition through to shut down.

In 'MANUAL MODE' you can:

- Light the pilot.
- Turn on the main burner.
- Regulate the flame from low to high and back.
- Turn off the burner leaving just the pilot burning.

In 'TEMP MODE' you can:

- Set the room temperature so the stove automatically maintains that temperature.

In 'TIMER MODE' the fire:

- Turns on and off according to the set time periods.
- Automatically regulates the room temperature during the set periods.

TURNING THE APPLIANCE ON

Your remote can control the gas fire from pilot ignition through to shut down.

To turn the fire on press the OFF button and the UP button simultaneously. You hear several short signals.

The pilot and main burner ignite and the remote is now in Manual Mode.

TURNING THE APPLIANCE OFF:

Press the OFF button to turn the appliance off
FOR SAFETY, YOU MUST WAIT 30 SECONDS BEFORE LIGHTING THE FIRE AGAIN.



IMPORTANT: YELLOW FLAMES TYPICALLY APPEAR WHEN THE APPLIANCE HAS REACHED NORMAL OPERATING TEMPERATURE. THIS CAN TAKE UP TO 30 MINUTES.



WARNING: IF THE APPLIANCE FAILS TO LIGHT OR BECOMES EXTINGUISHED IN USE, WAIT 3 MINUTES BEFORE ATTEMPTING TO RELIGHT.

FOR FULL OPERATING INSTRUCTIONS AND TROUBLESHOOTING SEE USER SECTION.

TROUBLESHOOTING



IMPORTANT: In the unlikely event that the handset fails to communicate correctly with the appliance it may be necessary to turn off the gas supply at the isolation valve until any problems can be resolved.

The gas meter and isolation valve can be located outside in a meter box, under the stairs, beneath the kitchen sink or in the garage. Whilst this list is not exhaustive, it is important to be able to identify the location of the valve in case of any gas emergency.

To turn off the gas supply, simply turn the handle so the lever is at 90 degrees to the upright gas pipe.

If you smell gas, open doors and windows and never operate any electrical switches. Immediately call the Gas Emergency Services on 0800 111 999.

COMMISSIONING

Complete the Commissioning Checklist at the front of this manual covering:

- Thermocouple soundness checks.
This is to include ensuring the thermocouple is secure on the pilot bracket assembly, lead connection and integrity.
- Flue checks
- Gas checks
- Log layout - flame picture

For working pressure test, refer to Technical Specifications.

Ensure all safety checks listed in the Commissioning Section are completed, paying particular attention to the glass panel checks and securing of the glass frame.

Upon completion of the commissioning and testing of the installation and correct operation of the appliance, the installer must instruct the user how to operate the appliance.

Guide the user through the User Instructions paying particular attention to:

- a) Regular servicing.
- b) Ventilation - point out the ventilation positions where applicable.
- c) Hot surfaces.
- d) How the appliance works with the remote control handset and the modes of operation.
- e) How to change settings in the auto mode and program modes of operation.
- f) What to do if the appliance fails to operate.

REPROGRAMMING HANDSET/CONTROL BOX

To access the control box see Servicing Instructions, Main Control Assembly.

- Press and hold the reset button on the control box until you hear two signals. After the second longer signal:
- Release the reset button and within 20 seconds:
- Press the DOWN button on the handset until you hear two additional short signals confirming the new code is set. If there is a single long signal the code learning sequence has failed or the wiring is incorrect.

SERVICING REQUIREMENTS

IMPORTANT – The glass panel on this appliance should be checked for any signs of damage on the front face of the glass panel (scratches, scores, cracks or other surface defects). If damage is observed, the glass panel must be replaced and the appliance must not be used until a replacement is installed. Under no circumstances should the appliance be used if any damage is observed. Please isolate the appliance until a replacement glass panel has been obtained and installed. Replacement glass panels can be purchased from Gazco via the retailer from which the appliance was purchased or any other Gazco distributor.

This appliance must be serviced at least once a year by a competent person.

All tests must be carried out in accordance with the current Gas Safe recommendations.

Before Testing:

- Conduct a gas soundness test for the property ensuring there are no leaks before servicing.
- Check the operation of the appliance before testing.

Special checks:

- Clean the burners using a vacuum cleaner with a soft brush attachment. Ensure all debris is removed from the burner ports.
- Clean away lint or fluff from the pilot.
- Clean away lint or fluff from under the burner.
- Check the spark gap on the pilot is correct.
- Check that the Pilot ignites correctly and Main Burner cross lights smoothly.
- Ensure that the glass is secured correctly and that all retaining screws are in place.

Correct any faults found during the initial test.

Re-commission the appliance in accordance with Commissioning Procedures of these instructions.

Advise the customer of any remedial work undertaken.

REPLACE BATTERIES BEFORE ATTEMPTING TO RECTIFY ANY FAULTS.

ELECTRONIC CONTROL VALVE FAULT ANALYSIS

SYMPTOM	CAUSE	REMEDY
Frequent beeps for 3 seconds after operation request	Batteries low in appliance	Replace appliance batteries
No ignition, 5 second continuous tone (there may be several short beeps before)	Loose/damaged wire	Check interrupter block and wires
No ignition, no tone, motor turns slightly when operated	Receiver board damaged	Replace receiver
No pilot flame and control continues to spark	Thermocouple circuit wired incorrectly	Correct wiring
Pilot lights, control continues to spark, valve shuts down after 10 - 30 seconds	1. No spark at pilot burner 2. Loose/damaged wire	1. Rectify spark at pilot burner 2. Check interrupter and wires

FAULT FINDING CHARTS

IGNITION FUNCTIONAL CHECK 1

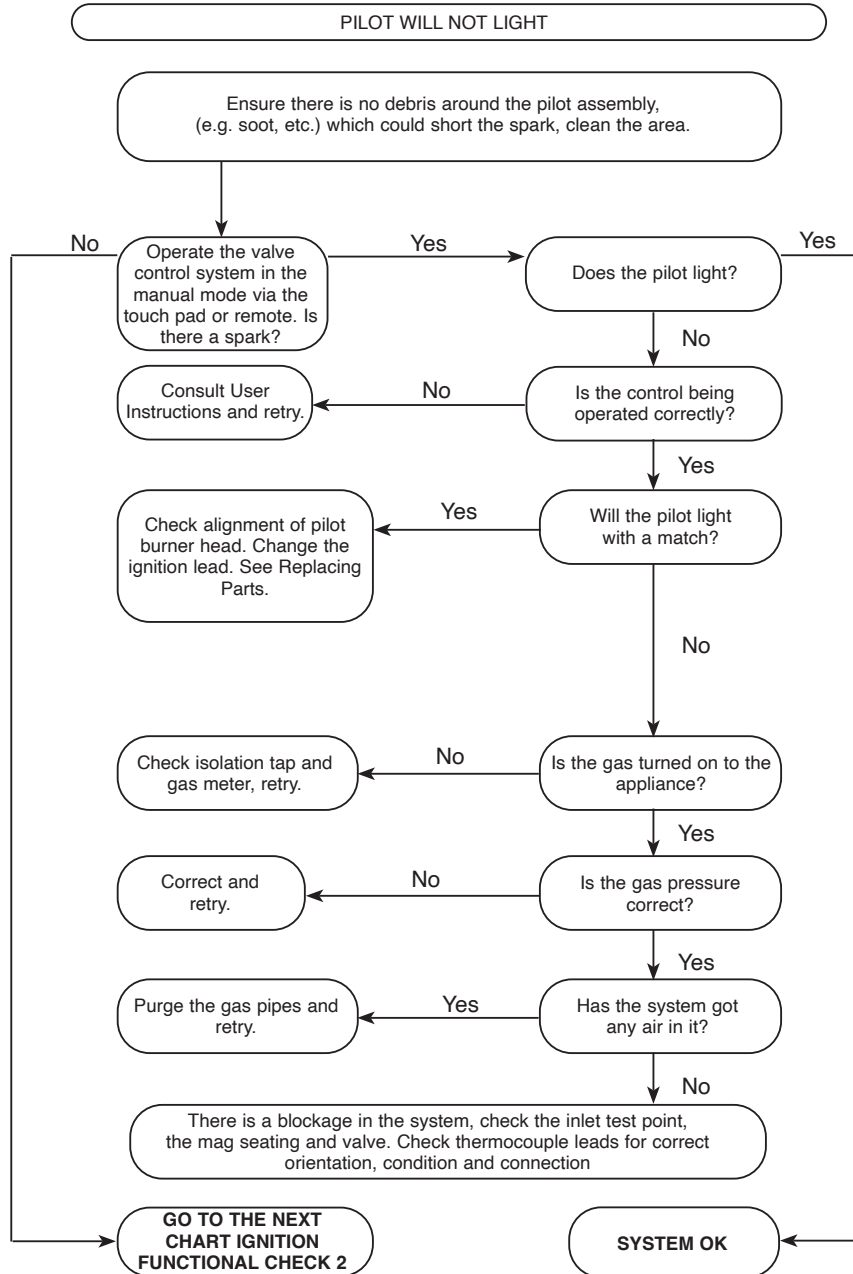

FAULT FINDING CHARTS

FLAME FAILURE FUNCTIONAL CHECK 3

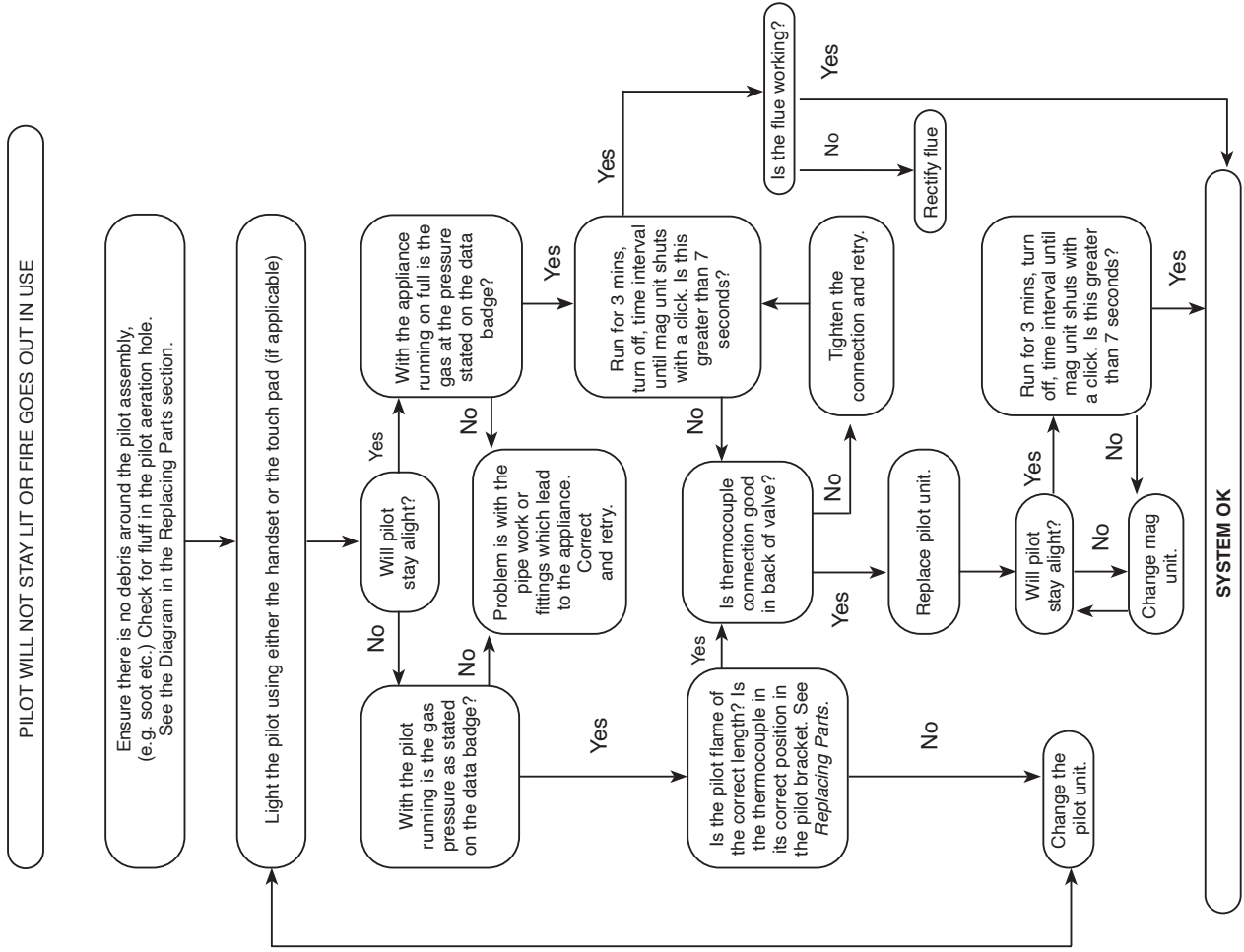

IGNITION FUNCTIONAL CHECK 2

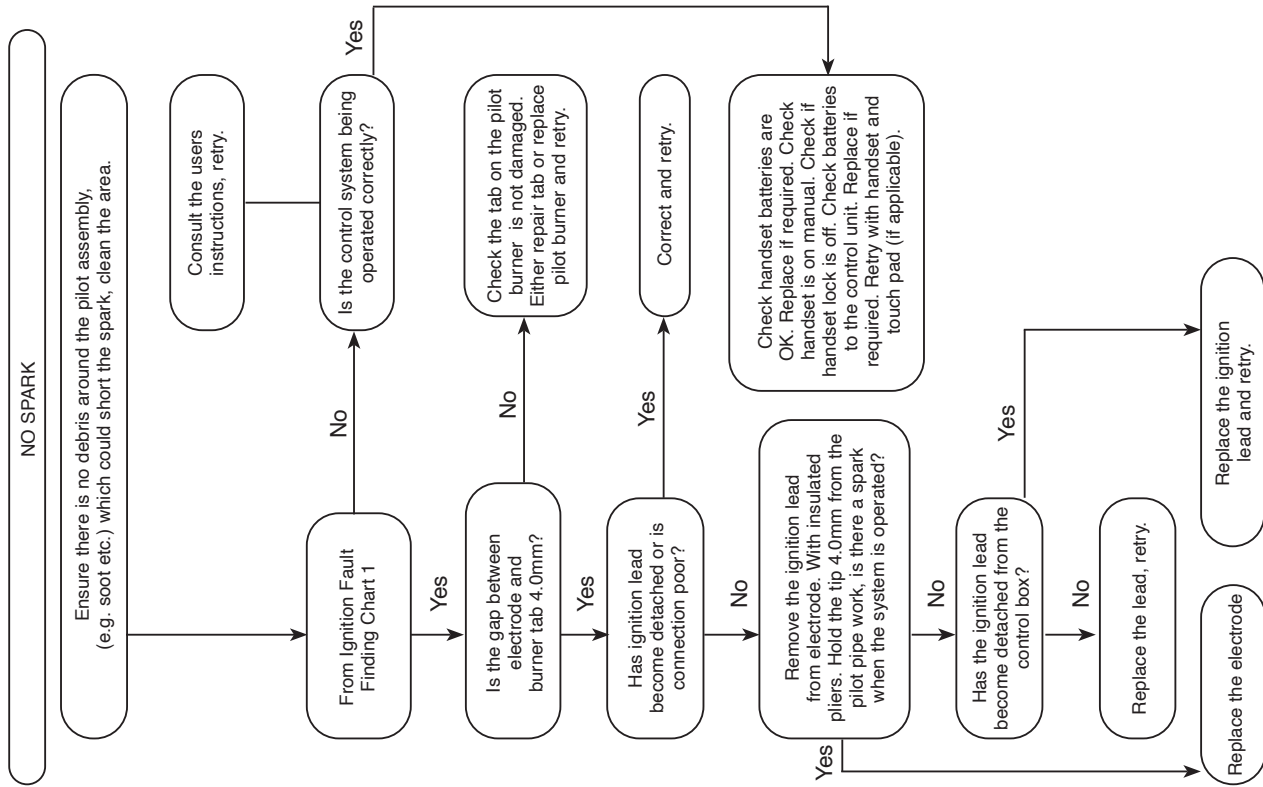

SERVICING

GENERAL

All main components can be replaced without removing the appliance from its installation.

IT IS ESSENTIAL THAT THE GAS SUPPLY TO THE APPLIANCE IS TURNED OFF AT THE ISOLATION DEVICE BEFORE PROCEEDING FURTHER.

DISCONNECT BATTERIES BEFORE SERVICING THE APPLIANCE.

Access to the controls is restricted and the whole control assembly must be removed as one unit, see Main Control Assembly.

SERVICING AND SUPPORT



Servicing and Support

To keep your appliance looking and performing at its best, it must be serviced annually. This service must be undertaken by a suitably qualified individual and your retailer can organise this for you. Alternatively, Gazco offer a manufacturers premium service with our friendly team of qualified engineers which can be booked at www.gazco.com/support

In all correspondence always quote the Model number and the Serial number which may be found on the Commissioning Checklist (Page 3).

DECORATIVE FRAME

The same method is used to remove each frame.

Lift the frame upwards off the four support brackets, see Diagram.

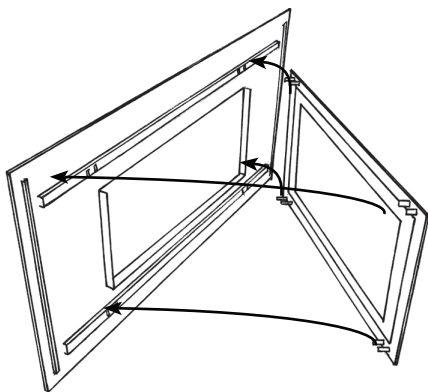

NOTE: THE STEEL FRAME IS HEAVY. TAKE CARE WHEN LIFTING.

WINDOW FRAME ASSEMBLY

To open the glass door use the hexagon key provided.

Release the window locks by moving them from shut to open towards the outer edges, see Diagram.

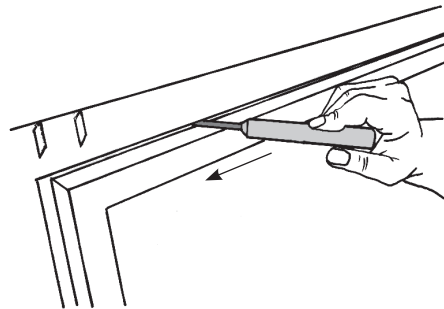

To completely remove the glass front:

Support the frame and lower it gently forward down to its natural stop position, see Diagram.
DO NOT EXERT PRESSURE ON THE DOOR ONCE THERE IS RESISTANCE.

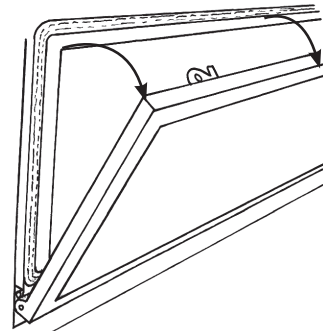

Remove the securing spring clip from the bottom-right of the window frame, see Diagram.

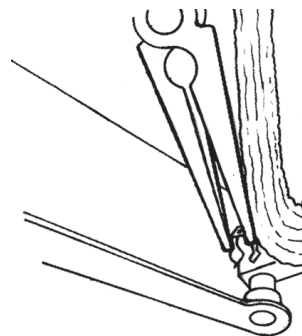

With the window frame in an upright position slide the frame to the left so that it comes off the left hinge pin, see Diagram.

Still keeping the frame upright drop the left side down and forward slightly, see Diagram.

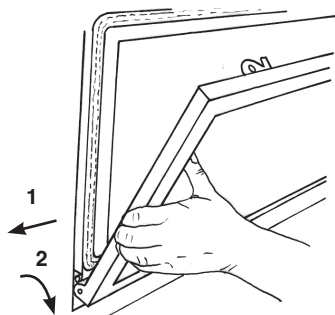

Slide the frame to the right so it comes off the **right** (all models) **and middle** (Studio 2 only) hinge pins. The window frame should now be free.

Place carefully to one side.

Refit the Window Frame Assembly in reverse order.

When closing the door ensure the door catches are fully engaged.

! UNDER NO CIRCUMSTANCES SHOULD THE APPLIANCE BE USED WITHOUT THE CATCHES HOLDING THE DOOR IN PLACE.

GLASS WINDOW

Remove the two clips and brackets from either side of the frame, see Diagram.

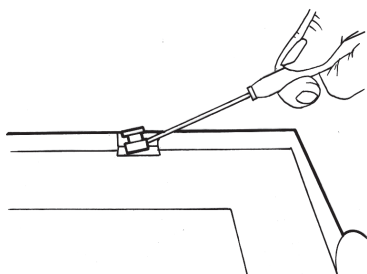

Lift the glass clear from the lock bracket at the top of the frame and slide out.

REMOVAL & FITTING OF THE LINERS

The Slimline Studio appliance comes with 4 optional liner finishes:

- Vermiculite
- Black Reeded
- Brick Effect
- Black Glass Linings - see separate instructions for fitting,

Slide the two side liners forward until clear of the appliance, see Diagram.

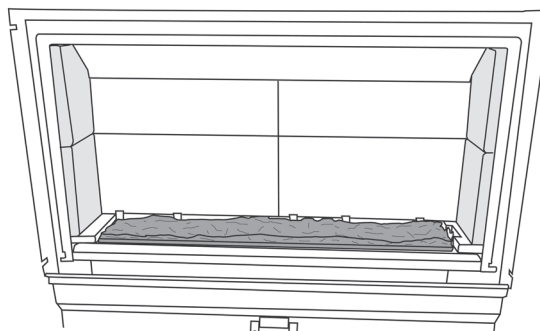

Remove the two clips holding the back panel in place, see Diagram.

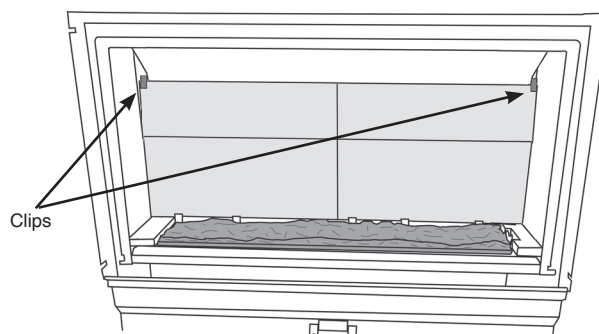

Remove the back panel then the two Bottom Side Liners, see Diagram.

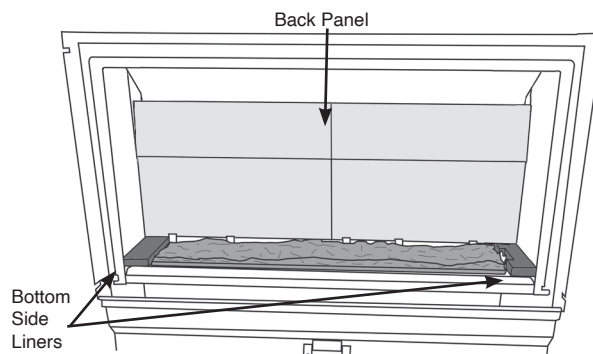

Replace the liners in reverse order.

MAIN BURNER

To replace the main burner:

Remove the fuel effect from the burner.

Remove the 3 (Studio 1) / 4 (Studio 2) screws securing the burner bracket(s) from the front of the burner, see Diagrams.

Studio 1 Slimline

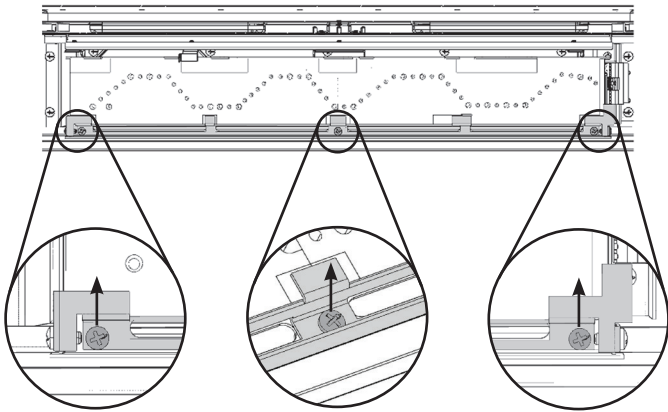

Studio 2 Slimline

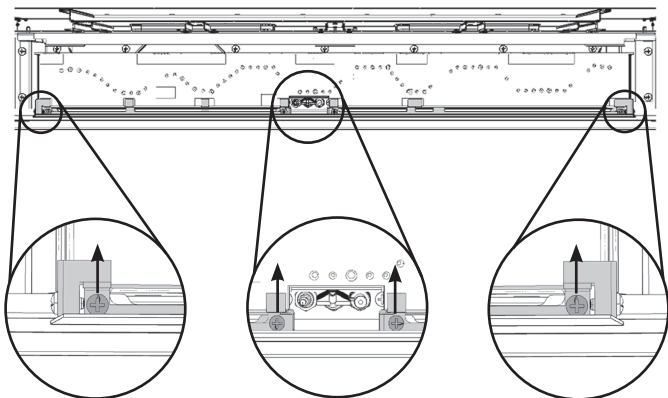

IMPORTANT

When replacing the main burner make sure that the brackets are replaced with screws.

Lift the burner up and out of the appliance.

To do this:

Studio 1 Slimline and Studio Slimline 2 Natural Gas

Lift the burner vertically to remove.

Refit in reverse order, ensuring the venturi engages with the main injector.

Studio Slimline 2 LPG only

Slide the burner to the left until the bracket prevents any further travel. Lift the left hand side of the burner tray and remove, see Diagram.

Studio 2 Slimline LPG only

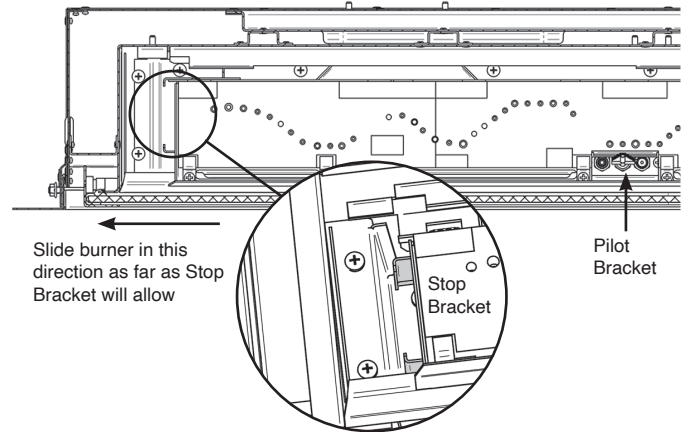

To replace position the burner as far to the left as possible and gently lower.

Slide the burner to the right carefully ensuring the venturi engages with the main injector.



WARNING: TAKE CARE NOT TO DAMAGE THE PILOT BRACKET COMPONENTS WHEN REPLACING.

ALL MODELS

When refilling the stone chippings, fill the tray making sure the effect is flattened so it is level with the rim of the tray.

DO NOT OVERFILL THE BURNER TRAY.

Ensure no stone chippings fall into the air slots at the front of the burner.

MAIN CONTROL ASSEMBLY

To access the main control assembly first remove:

- The decorative frame
- Window frame
- Liners
- Main burner

To remove the access panel:

Undo the two screws, see Diagram.

Note the orientation of the access panel with the return edges facing forward.



Isolate the gas supply at the isolation device and disconnect the gas inlet, see Diagram.

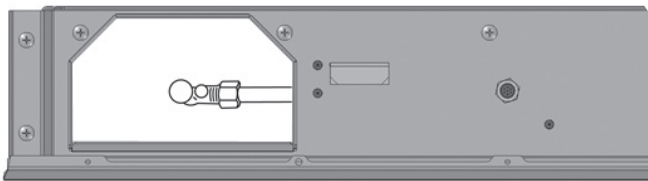

Remove the 9 (Studio Slimline 1) or 11 (Studio Slimline 2) screws securing the control assembly, see Diagram.

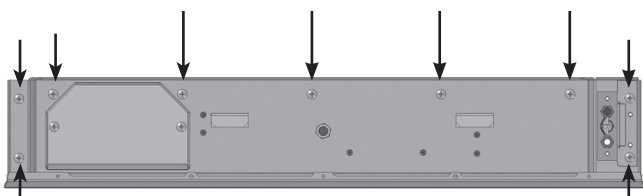

Studio Slimline 1 shown - Studio 2 model has more screws all rear of control assembly

The control assembly can now be lifted up and out of the appliance.

Disconnect the battery supply cable from the control unit.

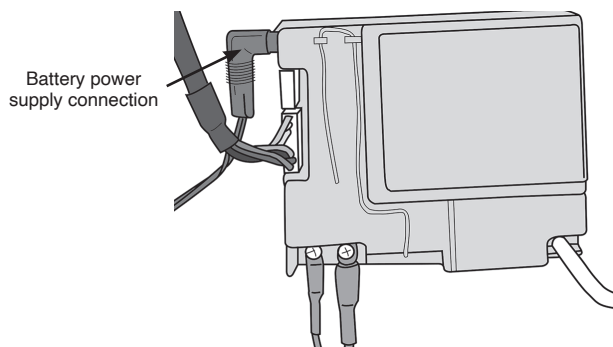

Reassemble in reverse order.

Note: Ensure no wires are trapped when replacing the assembly and that the foam seal is fully intact.

Replace the front two screws first, finger tight.
IMPORTANT: DO NOT CROSS THREAD.

It may be necessary to place a screwdriver through one of the central holes in order to align the fixing holes.

PILOT UNIT ASSEMBLY



IMPORTANT: UNDER THE TERMS OF THE EXTENDED WARRANTY IT WILL BE COMPULSORY TO CHANGE THE COMPLETE PILOT UNIT ON THIS APPLIANCE IN YEARS 2 AND 4.

The pilot assembly consists of four components which can be individually changed:

- Pilot burner bracket.
- Electrode
- Pilot Injector
- Thermocouple.

Before commencing work on the pilot the Main Control Assembly must be removed, see Main Control Assembly section.

PILOT BURNER BRACKET

To remove the Pilot Burner Bracket:

First remove the electrode, pilot pipe and thermocouple see Pilot Unit Assembly sections.

Remove the two screws securing the bracket. The pilot burner bracket can now be removed.

Studio 1 Only: Check the pilot gasket and if damaged, replace with a new one.

Replace in reverse order.

ELECTRODE

Pull the ignition lead off the electrode and undo the retaining nut, see Diagram.

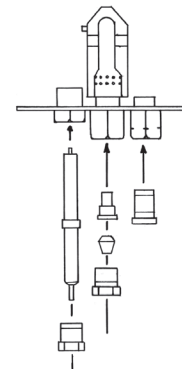

Replace with a new electrode. Do not over-tighten the nut; this could break the component.

Replace the ignition lead.

PILOT INJECTOR

Undo the pilot pipe from the gas valve and from the underside of the pilot burner, see Diagram.

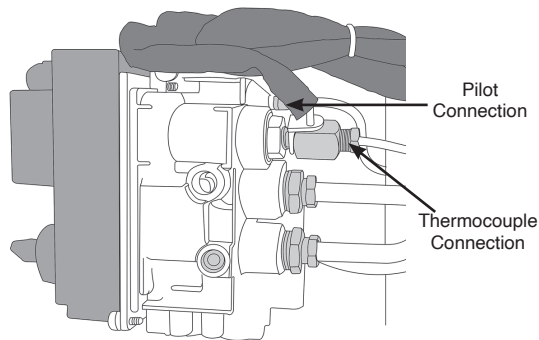
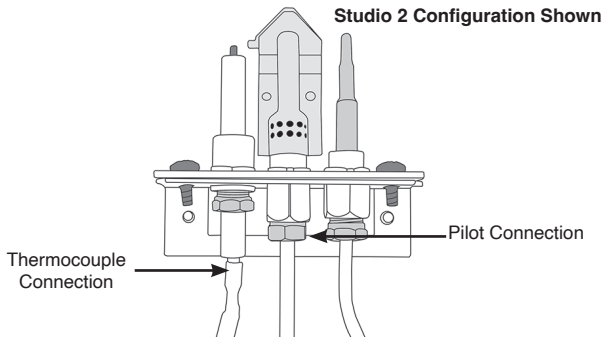

Remove the pipe and the injector drops out from the burner.

THERMOCOUPLE

Disconnect the thermocouple from the gas valve/interrupter, see previous diagram.

Note the position of the interrupter leads. The lead with the blue tag **MUST** be placed furthest away from the gas valve.

Undo the thermocouple nut in the back of the pilot bracket half a turn, see Electrode diagram. This releases the thermocouple.

STUDIO SLIMLINE 2 ONLY

This model has a U shaped bracket that secures the cables as they pass through the bulkhead.

This is held in place by a single screw.

Remove the screw and clean away any sealant.

The cables can now be withdrawn.

When replacing the cables apply fresh sealant and secure in place with the bracket.

ALL MODELS

When replacing with a new thermocouple, take care to bend the new component to the same shape as the thermocouple just removed.

To refit the thermocouple into the pilot bracket, ensure it is pushed fully into the hole. There is a stop on the thermocouple to set the height.

Lock the retaining nut just enough to grip the thermocouple.

Connect the thermocouple to the valve/interrupter **taking care not to over-tighten.**

IGNITION LEAD

To replace the ignition lead:

Remove the Main Control Assembly.

Remove the ignition lead from the control box, see Diagram.

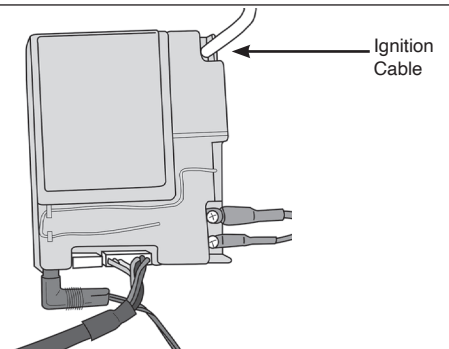
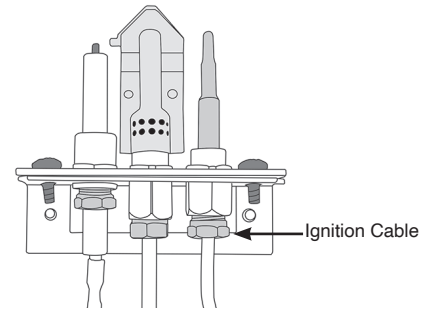

Remove the ignition lead from the electrode, see Diagram, remove cable ties where necessary.

Note the direction of the lead. The new lead must follow exactly the same route. Replace cable ties where necessary.

GAS VALVE

To change the gas valve:

Remove the Main Burner.

Release the gas inlet pipe, see Diagram, Arrow A.

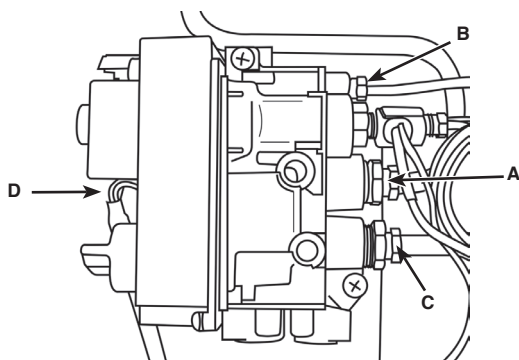

Remove the thermocouple from the interrupter block.

Release the pilot pipe, see Diagram, Arrow B.

Release the gas outlet pipe, see Diagram, Arrow C.

Remove the eight wire loom, see Diagram, Arrow D.

Remove the two screws securing the valve to the support bracket and withdraw the valve.

Replace in reverse order.

MAGNETIC SAFETY VALVE

To replace the magnetic safety valve:

Remove the Main Control Assembly.

Undo the thermocouple from the interrupter block and remove the two interrupter leads.

Unscrew the interrupter block from the back of the valve.

Undo the silver magnetic valve retaining nut on the back of the valve.

Gently tap out the mag valve.

Replace with a new unit.

Reassemble in reverse order ensuring that the interrupter leads are connected correctly with the blue tag lead furthest away from the gas valve body.

CONTROL BOX

To replace the control box first remove the main control assembly.

Remove the two thermocurrent cables by removing the two screws, Diagram.

Remove the ignition lead, Diagram.

Remove the eight wire loom from the control box.

Remove the battery extension cable, Diagram.

The control box can now be replaced.

When replacing the sealing plate on the rear of the control cover use a suitable silicone sealant.

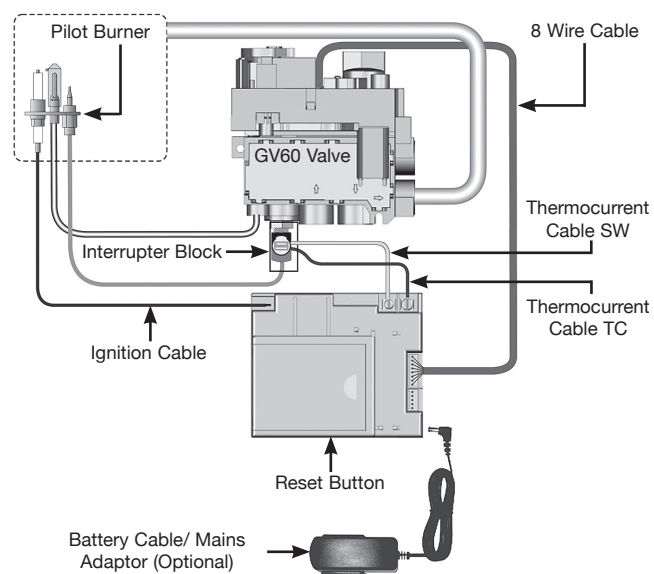

After replacing the control box you may need to reprogram the handset.

— Press and hold the reset button on the control box until you hear two signals. After the second longer signal:

— Release the reset button and within 20 seconds:

— Press the DOWN button on the handset until you hear two additional short signals confirming the new code is set.

If there is a single long signal the code learning sequence has failed or the wiring is incorrect.

MAIN INJECTOR

To change the main injector:

Remove the Main Control Assembly.

Undo the injector feed pipe.

Undo the lock nut from the injector.

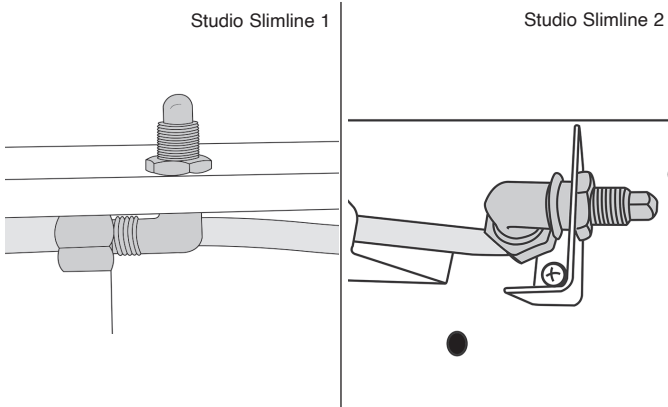

Replace with the correct size injector.

PRIMARY AERATION PLATE

The Aeration Plate is attached to the main burner unit and can not be replaced individually, see Diagram.

Studio Slimline 1 and Studio 2 Nat Gas

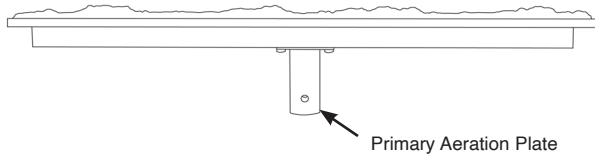

Studio Slimline 2 LPG

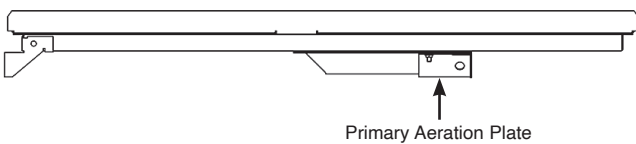

PRESSURE AND LEAK TESTING THE APPLIANCE

To gain access to the pressure test point, see Diagram and follow Main Control Assembly section.

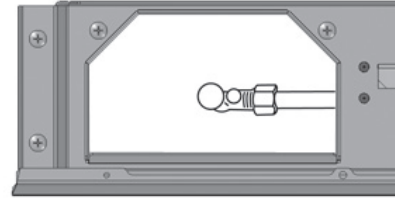

To leak test any gas joints on the appliance the control assembly must be undone and removed, see Diagram 3 in Main Control Assembly section.

Because there is now no burner fitted to perform a leak test, place a manometer tube over the injector tip.

Light the appliance and spray any joints with leak detector fluid.

Tighten joints or replace as required.

To check the inlet working pressure, replace the control assembly and connect a manometer to the pressure test point as depicted in Diagram.

Replace the burner and relight the appliance.

Operate the appliance at highest flame setting and check that the inlet pressure is in accordance with specifications detailed on page 14..

INFORMATION REQUIREMENT FOR GASEOUS FUEL LOCAL SPACE HEATER

Model	Studio 1 Slimline NG	Studio 1 Slimline LPG	Studio 2 Slimline NG Log	Studio 2 Slimline NG White Stone Effect	Studio 2 Slimline LPG	
Fuel	Space Heating Emissions (NOx) - mg / kWh _{input} (GCV)					
	130	130	130	130	130	
Heat Output	Nominal Heat Output - P_{nom}					
	3.8kW	3.8kW	4.5kW	4.5kW	5.0kW	
	Minimum Heat Output (indicative) - P_{min}					
	2.3kW	2.2kW	2.1kW	3.7kW	2.3kW	
Auxiliary Electricity Consumption	At Nominal Heat Output - e_{lmax}					
	N/A	N/A	N/A	N/A	N/A	
	At Minimum Heat Output - e_{lmin}					
	N/A	N/A	N/A	N/A	N/A	
	In Standby Mode - e_{sb}					
	N/A	N/A	N/A	N/A	N/A	
Useful Efficiency (NCV)	Useful Efficiency at nominal heat output - $\eta_{th,nom}$					
	82%	82%	82%	82%	82%	
	Useful Efficiency at minimum heat output (indicative) - $\eta_{th,min}$					
	72%	72%	72%	72%	72%	
Permanent Pilot Flame Power requirement	Permanent Pilot Flame Power requirement (if applicable) - P_{pilot}					
	N/A	N/A	N/A	N/A	N/A	
Type of heat output/room temperature control						
Electronic room temperature control + day timer		Yes	Yes	Yes	Yes	Yes
Other control options (multiple selections possible)						
Room temperature control, with presence detection		No	No	No	No	No
Room temperature control, with open window detection		No	No	No	No	No
With distance control option		No	No	No	No	No
With adaptive start control		No	No	No	No	No
With working time limitation		No	No	No	No	No
With black bulb sensor		No	No	No	No	No
Energy Efficiency Index		78%	78%	78%	78%	78%
Energy Efficiency Class		C	C	C	C	C
Contact:	Gazco Ltd, Osprey Road, Sowton Industrial Estate, Exeter, EX2 7JG					

STUDIO 1 SLIMLINE - SPARE PARTS

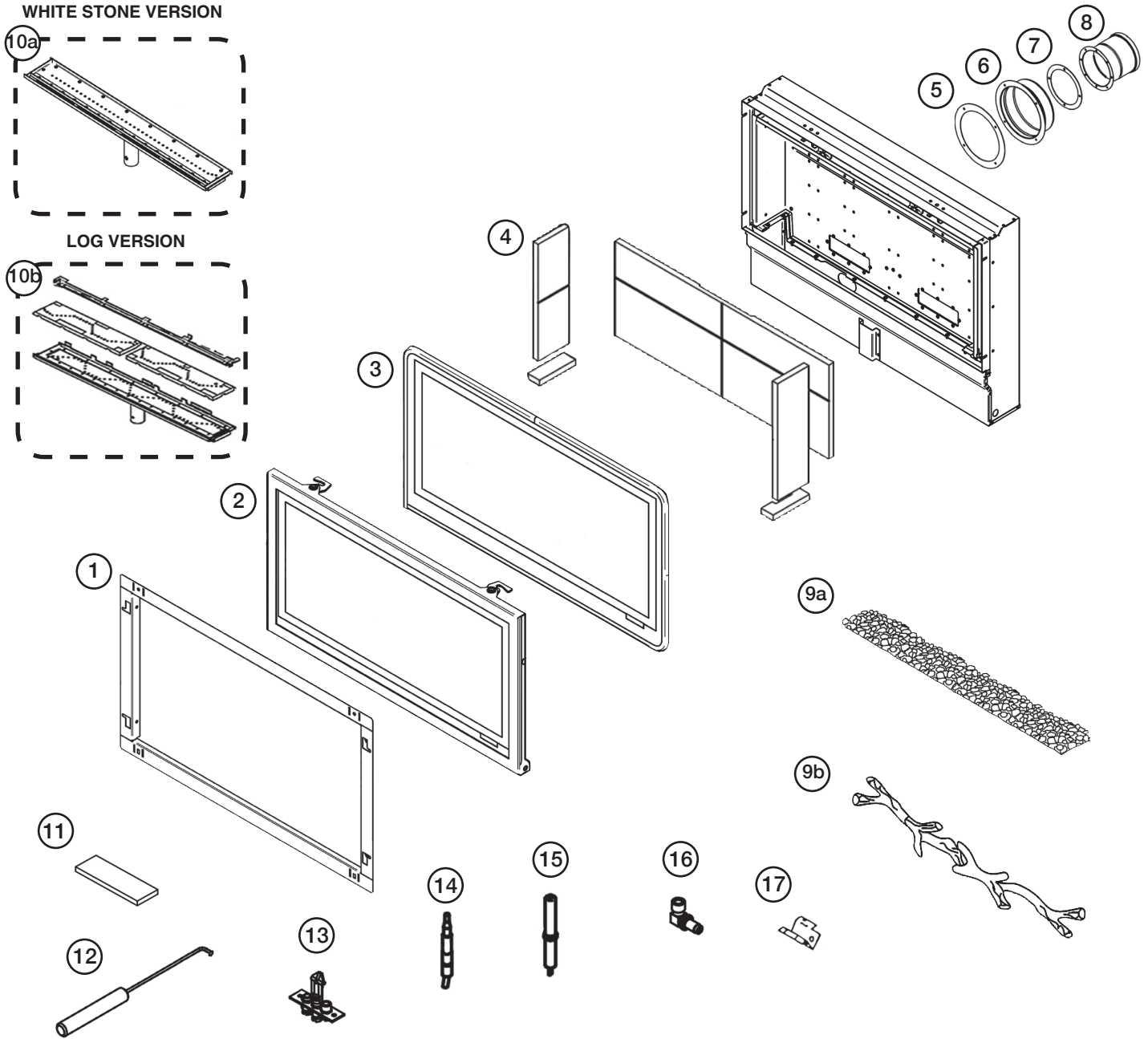

GAS TYPE	1	2	3	4	5	6	7	8	9a (WHITE STONES)	9b (LOGS)	10a (WHITE STONES)	10b (LOGS)	11
LPG	GZ9892	GZ10488	GZ10549	See Page 56	CE0211	MEC0269	CE0210	MEC0275	CE1094	CE1187	GZ10551	GZ16031	GZ8471
Nat. Gas												GZ10550	

GAS TYPE	12	13	14	15	16	17
LPG	GZ6690	PI0070	PI0074	PI0075	IN0053 S170	GZ10413
Nat. Gas		PI0069			IN0031 S150	GZ10579



Due to continual technical improvements please check online or with your Gazco retailer for the most up to date parts lists.

Only use Genuine Gazco spares when servicing your appliance.
All of our essential spare parts and consumable items are available to purchase from our webshop at www.gazcospares.com.

STUDIO 2 SLIMLINE - SPARE PARTS

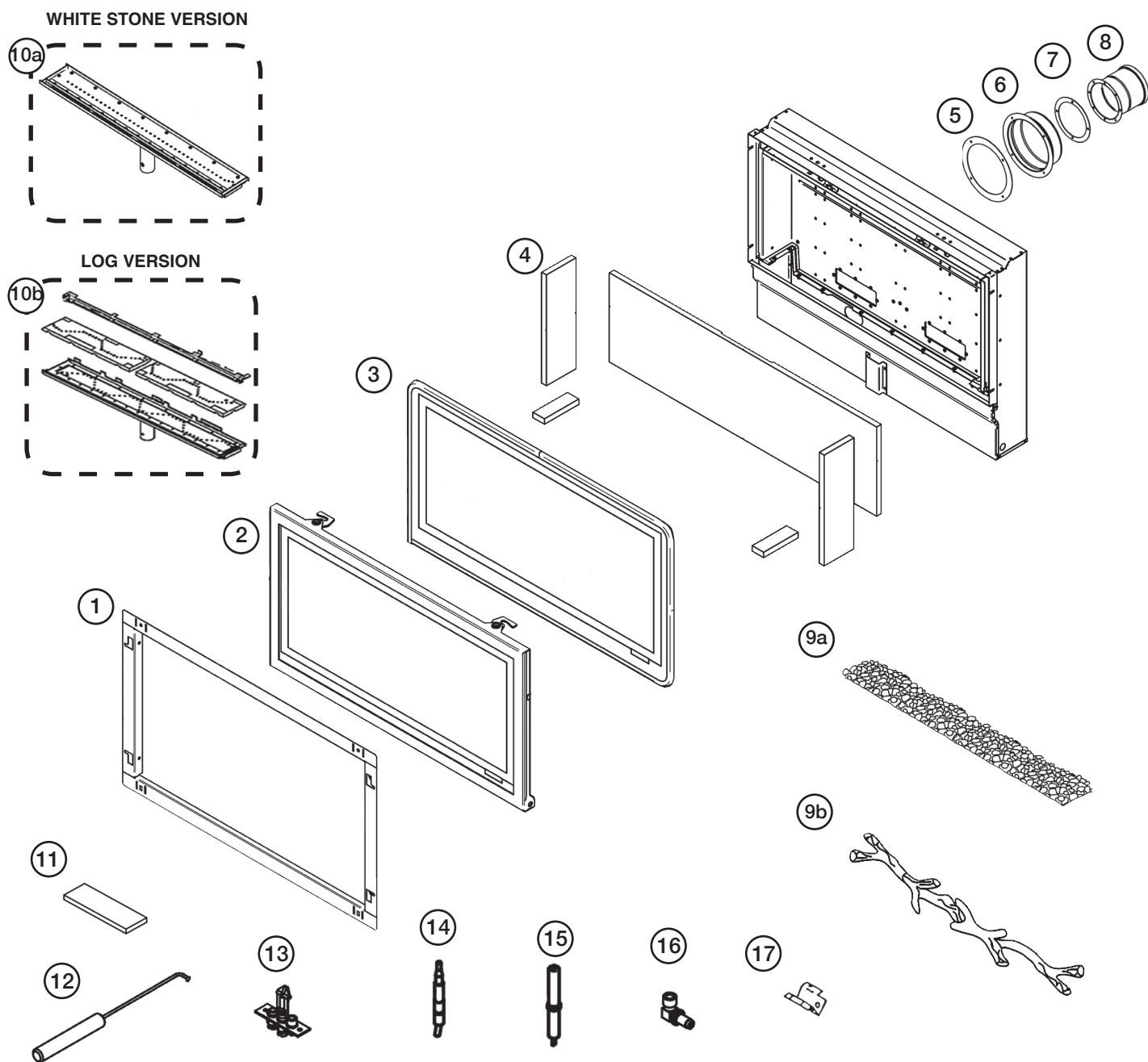

GAS TYPE	1	2	3	4	5	6	7	8	9a (WHITE STONES)	9b (LOGS)	10a (WHITE STONES)	10b (LOGS)
LPG	GZ11647	GZ11650	GZ11653	See Page 56	CE0211	MEC0269	CE01210	MEC0275	CE1094	CE1423	GZ13171	GZ16033
Nat. Gas											GZ12137	GZ16032

GAS TYPE	11	12	13	14	15	16	17
LPG	GZ8471	GZ6690	PI0070	PI0074	PI0075	IN0040 S185	GZ10413
Nat. Gas			PI0069			IN0061 S184	GZ10579



Due to continual technical improvements please check online or with your Gazco retailer for the most up to date parts lists.

Only use Genuine Gazco spares when servicing your appliance.
All of our essential spare parts and consumable items are available to purchase from our webshop at www.gazcospares.com.

STUDIO SLIMLINE - SPARE PARTS - LINING SETS

STUDIO 1 SLIMLINE

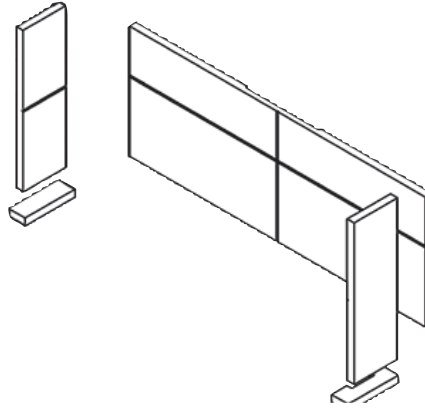

STUDIO 2 SLIMLINE

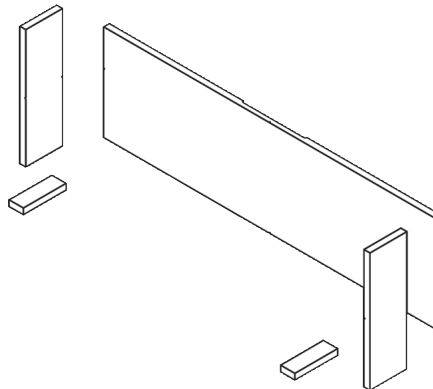

MODEL	LINING SET			
	BLACK REEDED	VERMICULITE	BLACK GLASS	BRICK EFFECT
STUDIO1 SLIMLINE	923-726	923-733	923-124	923-765
STUDIO2 SLIMLINE	923-226	923-257	923-314	923-273



Due to continual technical improvements please check online or with your Gazco retailer for the most up to date parts lists.

Only use Genuine Gazco spares when servicing your appliance.

All of our essential spare parts and consumable items are available to purchase from our webshop at www.gazcospares.com.

CONTROL ASSEMBLY (ALL MODELS) - SPARE PARTS

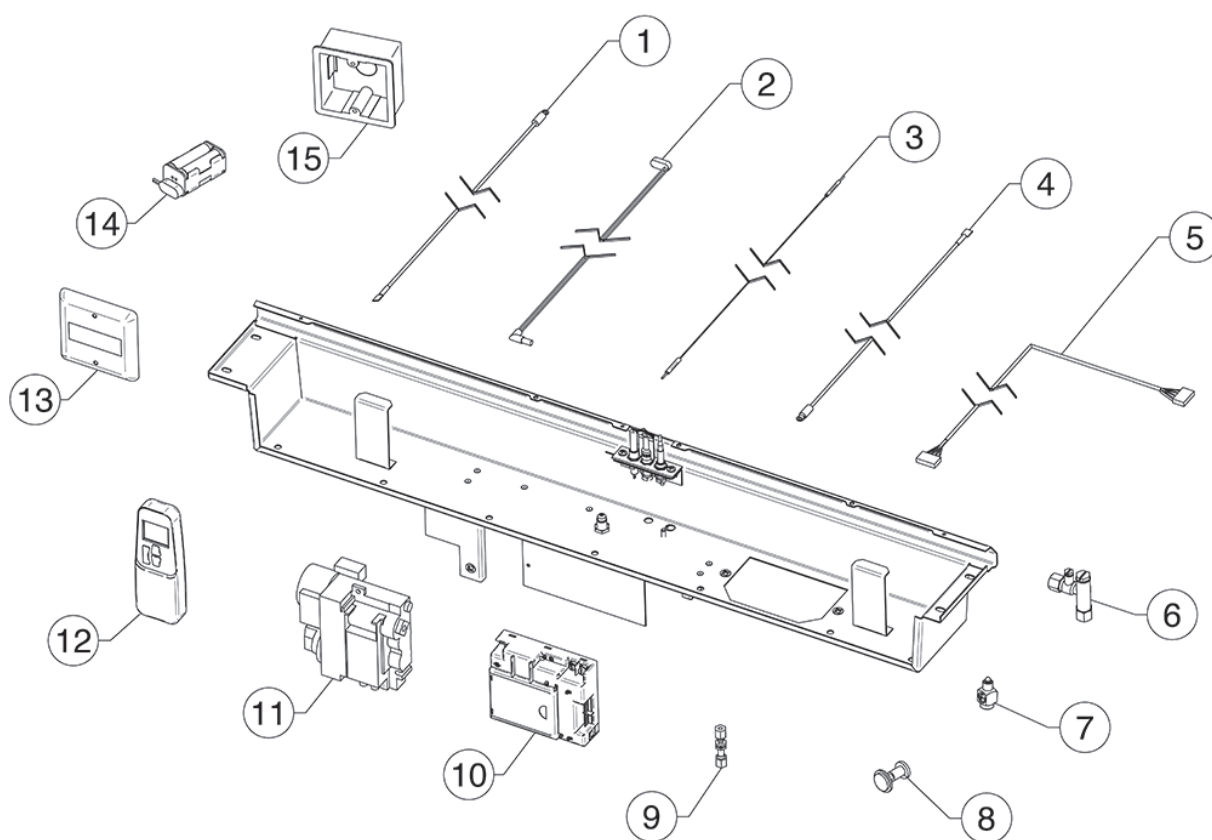

NO.	COMPONENT	PART CODE		QUANTITY
		STUDIO 1	STUDIO 2	
1	Thermocurrent Cable		EL0590	1
2	3m Battery Cable		GC0138	1
3	Ignition Cable		GC0125	1
4	Thermocurrent Cable		GC0136	1
5	350mm Connection Cable		GC0133	1
6	Pressure Test Restrictor Elbow		GC0095	1
7	Interrupter Block		GC0124	1
8	Magnetic Unit		GC0166	1
9	Bulkhead Fitting	N/A	FA0270	1
10	Receiver		GC0589	1
11	Control Valve		GC0123K	1
12	Thermostatic Handset		EL0571	1
13	Battery Access Cover		EL0591	1
14	Battery Holder		EL0410	1
15	Wall Box		EL0409	1



Due to continual technical improvements please check online or with your Gazco retailer for the most up to date parts lists.

Only use Genuine Gazco spares when servicing your appliance.

All of our essential spare parts and consumable items are available to purchase from our webshop at www.gazcospares.com.

SERVICE RECORDS

1ST SERVICE

Date of Service.....
Next Service Due
Signed
Retailer's Stamp/GasSafe Registration Number

3RD SERVICE

Date of Service.....
Next Service Due
Signed
Retailer's Stamp/GasSafe Registration Number

5TH SERVICE

Date of Service.....
Next Service Due
Signed
Retailer's Stamp/GasSafe Registration Number

7TH SERVICE

Date of Service.....
Next Service Due
Signed
Retailer's Stamp/GasSafe Registration Number

9TH SERVICE

Date of Service.....
Next Service Due
Signed
Retailer's Stamp/GasSafe Registration Number

2ND SERVICE

Date of Service.....
Next Service Due
Signed
Retailer's Stamp/GasSafe Registration Number

4TH SERVICE

Date of Service.....
Next Service Due
Signed
Retailer's Stamp/GasSafe Registration Number

6TH SERVICE

Date of Service.....
Next Service Due
Signed
Retailer's Stamp/GasSafe Registration Number

8TH SERVICE

Date of Service.....
Next Due
Signed
Retailer's Stamp/Gas Safe Registration Number

10TH SERVICE

Date of Service.....
Next Service Due
Signed
Retailer's Stamp/GasSafe Registration Number

FOR ENQUIRIES IN THE U.K (EXCLUDING NI):

Gazco Limited, Spitfire Avenue, Skypark, Clyst Honiton, Exeter, Devon, England EX5 2FR

Tel: (01392) 261900 E-mail: info@gazco.com

FOR ENQUIRIES IN EUROPE (INCLUDING NI):

Stovax Heating Group (NI) Ltd (Comp reg NI675194), 40 Linenhall Street, Belfast, BT2

8BA DX 400 NR Belfast Tel: +44 (0)1392 261990 E-mail: northernireland@gazco.com

E & O E

